

# THE HUNI PRODUCT RANGE

Italian Quality Equipment for PRIVATE LABEL and OEM'S

**YOUR  
BRAND  
YOUR  
IDENTITY**



**OUR  
COMPANY**

**OUR  
PRODUCTS**



\*Customization  
is possible upon request,  
for any design need.

# HUNI, YOUR PARTNER

Huni gives you visibility. Successful, experienced and systematic. For more than 60 years, the company has enabled its customers to work in a more orderly and efficient way, offering them not only a high-quality product, competent advice and a wide range of services, but also perfectly integrated solutions to simplify workflows thanks to the Huni system. This makes Huni one of the world's leading partners in workshop and warehouse equipment.



## BENEFITS AT A GLANCE

- **Complete range**  
From access controls to bases.
- **Modular construction**  
This allows all products to be freely combined.
- **Ultimate flexibility**  
Thanks to a wide range of colours, individual configuration options and much more.
- **Custom-built solutions**  
For customers with specific needs.
- **Precise design**  
Including our 3D design software.
- **10-year guarantee**  
Unique in the industry.
- **A range of additional services**  
Such as training, assembly, labelling, etc.
- **Worldwide sales and service network**  
For customer care without boundaries.
- **Top references**  
From prestigious companies around the world.

# THE HUNI PROGRAMME



Huni profile

04



Equipment characteristics and special features

08



Drawer cabinets

18



Drawer storage walls

50



NC storage and transport unit

70



Workstation systems and benches

80



Cabinet solution

100



Partition material and labelling system

104

# WITH HUNI YOU GET MORE

From your favourite colour to the perfect drawer partitioning - it is important to us to offer you the right product for your needs. That's why Huni is versatile in any industry. Our surfaces, for example, are available in an ESD version or with an antibacterial coating, as well as in the desired individual colour. You can also implement multi-level locking options up to fully automatic access control, depending on your requirements. Not to mention the wide range of partition material, accessories and, last but not least, attractive accessories.

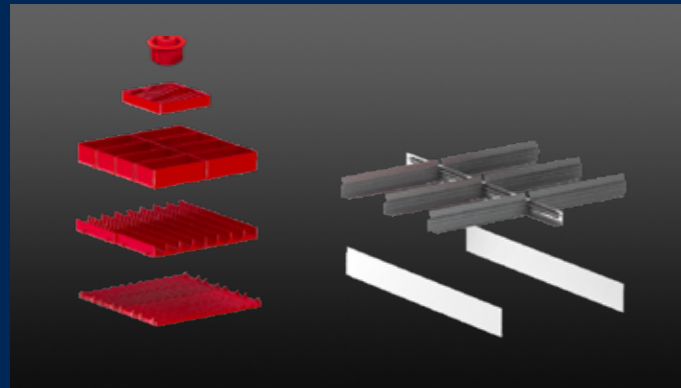

## WIDE RANGE OF PARTITION MATERIAL

Trays, troughs, anti-slide mats, dividers and much more - the right partition material keeps your Huni drawers tidy and helps ensure more efficient work processes and increased productivity. Refer to page 104.



## SMART ACCESSORIES

You can complete your Huni system with accessories such as hooks and lamps. Design every workstation ergonomically and tailored to your individual needs. Refer to page 80.

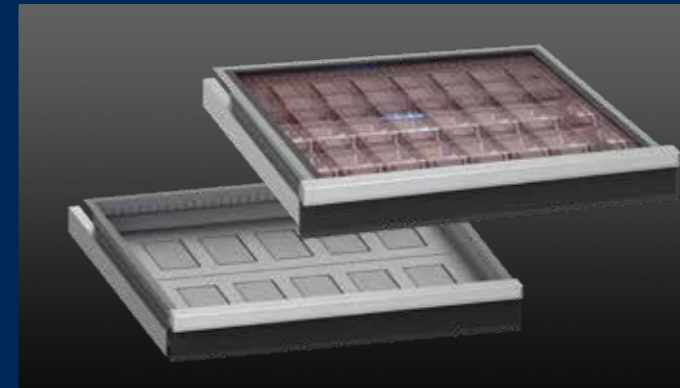

## ELECTRONIC ACCESS CONTROL

Use our electronically controlled access system to protect valuable and important stored goods particularly safely and efficiently. Refer to page 14.



## ESD SOLUTIONS

To protect components and construction elements sensitive to electrostatic discharge, your Huni equipment is also available in an ESD version. Refer to page 8.

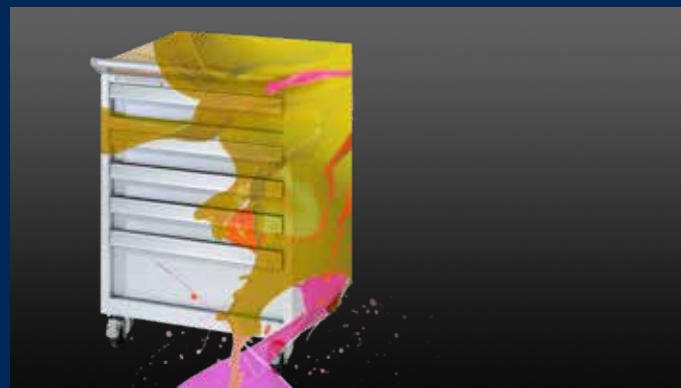

## WIDE RANGE OF COLOURS

11 standard colours and other colours available. Huni also offers you the perfect solution in terms of aesthetics. Discover the possibilities. Refer to page 25.



## FLEXIBLE LOCKING SYSTEMS

From the standard lock with exchangeable cylinder to the fully electronic control system, Huni offers you the optimal locking system for your needs. Refer to page 12.



## LIGHT ACCORDING TO BEACON

BEACON, Huni's design cabinet with LED light, promises add more personality to your workspace. Exciting. Different. State of the art. Refer to page 16.



# HUNI'S PROMISE

It's actually very simple - we want you to be satisfied with your Huni solution. That's why we put the customer at the centre of everything we do. For our products, this means: top quality combined with a long-term guarantee and responsibility for the future. This way, you can be sure that you will not only get a high-quality and long-lasting solution from Huni, but also a sustainable one.



## SUPERIOR INDUSTRIAL QUALITY

Huni products meet the highest quality standards. They are made of high-quality materials, are robust and have a first-class finish. That's why we offer a 10-year guarantee, virtually without exception. A unique case in the industry, but this is certainly not the only benefit you, as a Huni customer, can count on. Huni solutions are internationally certified and can therefore be used worldwide, for years and even decades, because we also guarantee after-sales service for your product, in addition to the best industrial quality.



## HIGHEST PRODUCTION STANDARDS

Our aim is to provide you with the Huni system with a consistently high level of quality. That's why we manufacture our products exclusively in Italy. State-of-the-art production techniques as well as continuous investments and innovation in our production processes ensure excellent results. For more than 60 years, Huni has been synonymous with reliability and safety as a partner for all aspects of warehouse and workspace equipment.



## QUALITY MANAGEMENT

In order to be able to improve our competitiveness and performance and thus also our customer satisfaction in the long term, we set ourselves realistic goals and constantly review them. Our quality and environmental management system meets all the requirements of the international standard ISO 9001:2015.



Organizzazione con Sistema di Gestione certificato ISO 9001



## SUSTAINABILITY

Ecology and sustainability begin with the development of our products and continue in all subsequent processes, from the procurement of raw materials, through production and distribution, to the long-term use of our solutions for cabinets, shelving and much more. Because of its 100% recyclability and its robustness and durability, we mainly use steel as a production material.





# SECURE LOGIN WITH ELECTRONIC COMPONENTS



## SAFETY FOR ELECTRONIC COMPONENTS

Controlled dissipation of electrostatic charges.



## COMPLETE ESD PRODUCT RANGE

For all applications (ranging from minimum to full protection).



## PRECISE DESIGN

ESD workstations and company equipment.



## COST SAVINGS

No damage and latent errors on the PCB.



## SECURE AND TRANSPARENT STORAGE

Electronic components.



**ESD stands for Electrostatic Discharge.** It is generated by the exchange of charges between two bodies with different voltage potentials. In modern working environments, electrostatic charge can cause high voltages depending on the humidity of the air.

### WHEN DOES ESD BECOME DANGEROUS OR HARMFUL?

Due to the low energy involved, the exchange of charges between two bodies is often not noticed. However, even small electric shocks can quickly lead to irreparable damage or cause hidden defects in electronic components. If ESD damage is not immediately detected, high repair or replacement costs may be incurred. And if an entire product batch is compromised, the most serious level of reputational damage is added to the financial loss, which in the worst case can lead to the loss of customers.

Therefore, the following principle must be observed: **"If you don't generate a charge, you don't even have a discharge."**

If equipment used for working on components at risk of ESD is protected against ESD, the risk of static discharge is minimised. This requires a comprehensive protection concept.



Warning signs for components at risk of ESD



ESD protective components

### HUNI'S COMPLETE ESD WORKSTATION OFFER

To prevent financial damage, Huni offers a complete ESD design and construction programme. Combining its many years of experience in workstation development with knowledge of ESD issues, Huni has created a complete ESD workstation offer: all **painted areas are provided with a coloured coating designed by Huni to dissipate charges in a controlled manner and prevent electrostatic discharges.**

### AN EXTENDED ESD PROTECTION ZONE INCLUDES THE FOLLOWING AREAS:



#### Workstations

The perfect ESD workstation is ergonomically adjustable and equipped with ESD protection. Electrostatic charges are discharged in a controlled manner through the working surface and a grounding cable, thus keeping the workstation system electrically neutral.



#### Grounding for personnel safety equipment

People are the main source of electrostatic charges. For those involved in the manufacture of electronic components, it is therefore advisable to use a wristband with a grounding cable and insulated footwear. In addition, the desk chair and standing aid should also be equipped with ESD protection.



#### Warehouse & Storage

Drawer cabinets or cabinets with closed ESD hinged doors and ESD shelves with ESD containers (Faraday cage) ensure optimum storage of electronic components.



#### Markings

Areas with ESD protection must be marked accordingly. In addition, construction components at risk must be marked with signs or other adhesive labels.



## INDIVIDUAL CONFIGURATION AND ORDERING OF ESD ZONES

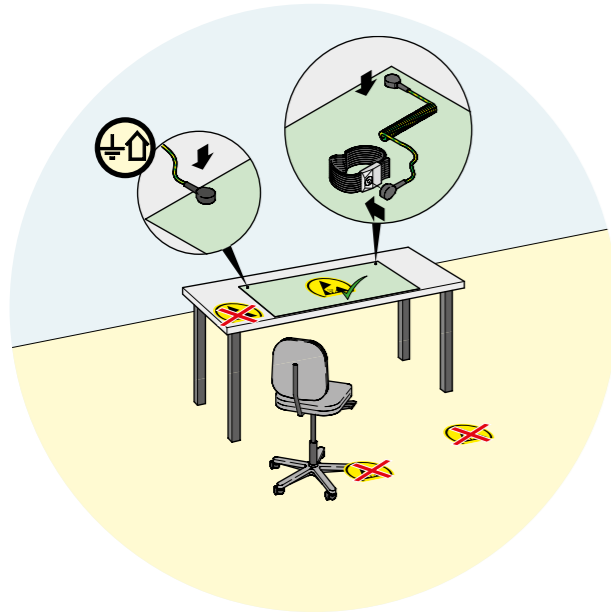

### 1 Variant A

#### Minimum ESD protection

- Antistatic table mat with wrist strap

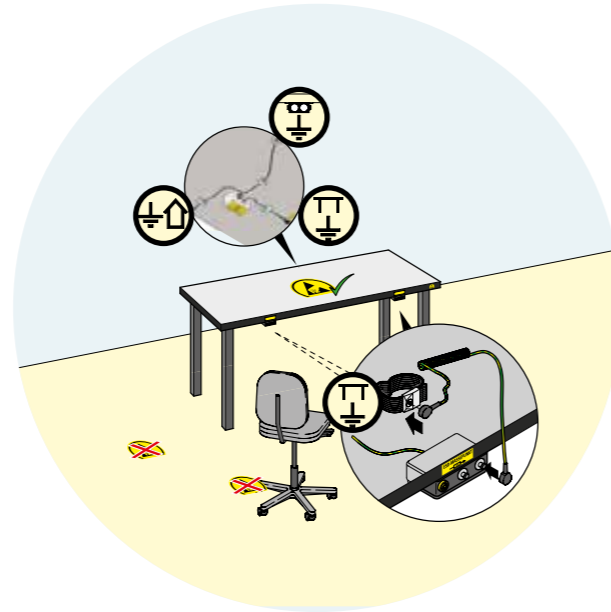

### 2 Variant B

#### Standard ESD protection

- Antistatic table top with wrist strap

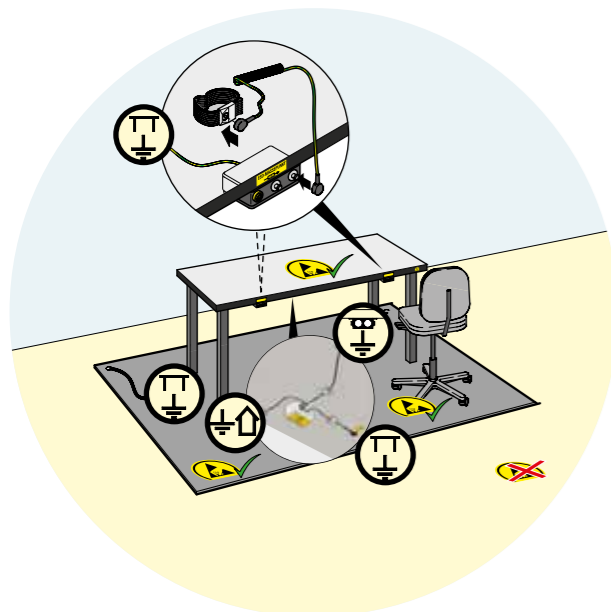

### 3 Variant C

#### ESD island

- Antistatic table top with wrist strap
- Antistatic desk chair
- Antistatic floor mat



### 4 Variant D

#### ESD protection zone

- Antistatic table top with wrist strap
- Antistatic desk chair
- Antistatic floor panel

## HOW DOES ESD AFFECT COMPANIES?

"You work on components without knowing if they will be damaged during production or not."

Checklist for equipping and maintaining ESD protection zones in order to comply with the following ESD principle: "If you don't generate a charge, you don't even have a discharge".

## ESD CHECKLIST FOR COMPANIES



# CUTTING-EDGE SAFETY SYSTEMS

## OVERVIEW OF THE HUNI ACCESS SOLUTIONS

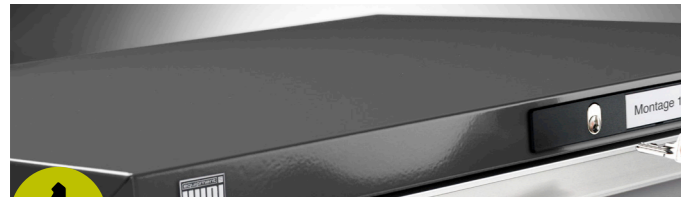

**KEY LOCK** Art. no. 820.002  
The proven standard lock

- KEY Lock, our standard locking system with exchangeable cylinder.
- Manual locking/unlocking with keys.
- Equally numbered lock for multiple, even different products, with a single key or separately lockable with several keys.
- After-sales key service guaranteed for years.



**CODE LOCK** Art. no. 820.011  
The number combination solution

- When locking with CODE Lock, the key is replaced by a number combination. A single 4- to 6-digit numerical code is sufficient to open the product.
- Manual opening/locking via numerical code.
- Reading and programming of the lock via our software (option).



**RFID LOCK** Art. no. 820.060  
The ideal solution for the future: the RFID badge

Huni's RFID Lock in addition to the CODE Lock offers opening and closing using the usual RFID radio frequency identification technology. It consists of a transponder in the lock and a commercially available mobile RFID badge, card or label.

- **Manual opening/locking** via RFID badge or numerical code.
- Most standard RFID badges, cards, labels can be used.
- Reading and programming of the lock via our software (option).



**AUTO-LOCK** Art. no. 820.066 (27 U)/820.067 (36 U)  
The ultimate solution: automatic opening and locking

Huni's AUTO Lock incorporates the same functionality as our RFID Lock, but opens or closes automatically. With our software (optional), time profiles can also be stored in the lock or on the user in case of increased security requirements.

- **Automatic opening/locking** via the RFID badge or numerical code
- Most standard RFID badges, cards, labels can be used.
- Closes automatically after a set period of time or at the push of a button
- Reading and programming of the lock via our software (option).
- Time-limited access programmable via our software (option).

The new generation of Huni locking systems stands for ease of use and state-of-the-art security. Modern technologies now make our electronic locks even more flexible and user-friendly. You can freely combine different systems and bundle them together in a locking option to optimally suit **your customer and their requirements**. We would be happy to give you some tips.

## HUNI LOCKING SYSTEMS IN DIRECT COMPARISON

	KEY Lock	CODE Lock	RFID Lock	AUTO Lock
<b>Manual access</b>				
Key	•	-	-	-
Max. number of different cylinders	as required	-	-	-
Max. number of locks	as required	-	-	-
<b>Electronic access</b>				
Code	-	•	•	•
Max. number of user codes	-	100	100	100
RFID	-	-	•	•
Max. number of locks	-	as required	as required	as required
Automatic locking/unlocking	-	-	-	•
<b>Management</b>				
Lock ID code	-	•	•	•
<b>Interfaces</b>				
Free contact for external systems	-	-	•	•

## WIDE RANGE OF ACCESSORIES FOR OUR LOCKING SYSTEMS



**Basic kit**  
1 AC/DC adapter (12 W/5 V)  
1 complete Combi-Lock connector  
1 set of assembly instructions  
4 cable ties  
Art. no. 820.050



**Extension kits**  
1 complete Combi-Lock connector  
1 connecting cable, 2 m  
4 cable ties  
Art. no. 820.051



**Extension cord kit**  
1 connecting cable, 2 m  
(one set required every two meters)  
Art. no. 820.052



**Programming badge**  
Set of 2 units, colour: black  
Art. no. 820.062



**User badge**  
Set of 5 units, colour: blue  
Art. no. 820.061



**RFID badge reader**  
for PC  
Art. no. 820.064



**Security eCard**  
2 pieces



# SAFETY AT EVERY LEVEL



## LESS MATERIAL LOSS AND PREDICTABLE INVENTORY

For direct cost savings and increased productivity.



## CONSTANT AVAILABILITY AND COMPLETE TRACEABILITY

24/7 hours of stored valuable articles.



## ULTIMATE FLEXIBILITY

Thanks to individual locking levels and access rights.



## ENHANCED SECURITY AND SAFETY

With specially developed metal compartments.



## SIMPLE OPERATION

With intuitive controls.



## OPTIMAL PROTECTION AGAINST UNWANTED ACCESS



The electronic access system **Electronic Control** ensures maximum flexibility in assigning and organising access authorisations. Whether you want to manage the entire cabinet, individual drawers or compartments specially developed for this purpose, or use all the different system variants in one cabinet. All according to your needs. We would be happy to give you some tips.

## THE MODULAR SYSTEM FOR INTRALOGISTIC SOLUTIONS

### CC - Cabinet Control

Electronic access to the entire cabinet.

Available in sizes:  
36 x 36 E (717 x 725 mm)  
54 x 36 E (1023 x 725 mm)

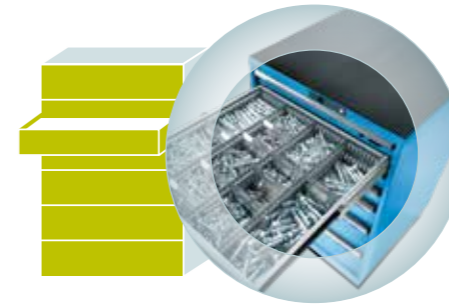

1 Access control at cabinet level

### DC - Drawer Control

Electronic access to individual drawers can be defined.

Available in sizes  
36 x 36 E (717 x 725 mm)  
54 x 36 E (1023 x 725 mm)

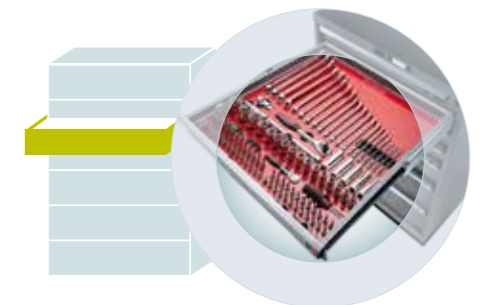

2 Access control at drawer level

## FIND INSTEAD OF SEARCH

Huni's Electronic Control offers a tailored software solution for the warehousing and access management of your Huni products. The software ensures optimal ordering, so you can quickly find the product you are looking for. eControl is simple, intuitive and event-programmed, so you can pick without a single registration. Optionally, the solution can be integrated into your existing ERP system via an interface and enables complete data-based and evaluation-based control in addition to complete transparency and time savings.

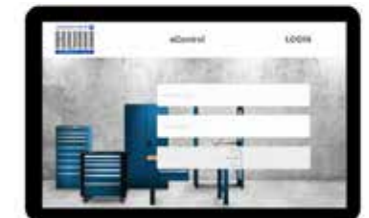

**Electronic Control** is available as a complete hardware and software system or as a single hardware for use with existing software.

# GET THE LOOK



GET THE LOOK



**Add personality to your workspace:** Discover BEACON, Huni's new design cabinet with LED technology. The latest addition is available in two different variants and sizes. Enjoy individual lighting in the workshop, sales area, studio and office.



INDIVIDUAL LIGHT FOOTPRINT



TWO VERSIONS: LIGHT STRIPE (LINE) OR DOTTED EFFECT (DOTS)



VISUAL HIGHLIGHTS



DIFFERENT LIGHT LEVELS



SOPHISTICATED LOOK



SUSTAINABLE LED TECHNOLOGY



## LIGHT STRIP PROFILE: BEACON LINE

- Vertical light bar along front left and right of the cabinet
- Geometric and uniform appearance
- Colour: white
- Available for cabinet height 850 mm (other versions available on request)



## DOTTED EFFECT PROFILE: BEACON DOTS

- Individually controllable LED elements in the handle corners
- Dynamic transmission from a technical point of view
- Available in four colours (colour mix and intensity can be customised with the optional myDOTS software package)
- Available for cabinet heights 700, 800, 850, 1000, 1150 and 1450 mm (other versions on request)



# ROBUST ALL-ROUNDER



## OUTSTANDING PROTECTION FEATURES

Protected against dirt, liquids and mechanical stress thanks to the closed cabinet body with impact-resistant and wear-resistant surfaces.



## FLEXIBLE ADAPTATION OPTIONS

With pre-punched holes for fixing wooden tops, castors, drawers and locking systems for simple replacement or reorganisation.



## COMPLETELY SECURE

Safety catch as standard to prevent drawers from falling out when pulled out and single-drawer blocking system to prevent the drawer unit from tipping over.



## OPTIMAL LEVEL OF ORDER AND ORGANISATION

Thanks to Huni's special partition material, perfect for every application, and perforated and slotted drawers.



## TOTAL UTILISATION

Thanks to complete extension and optimum drawer cladding height.



## SECURE LOCKING OPTION

With exchangeable cylinder for adaptation to existing locking systems and electronic locks with CODE, RFID or AUTO Lock.



## HIGHLY STABLE

Cabinet housings with a load capacity of up to 4 t, drawers with a load capacity of 75 or 200 kg.



## PROFESSIONAL LABELLING

Handle prepared for inserting labels.



## CORROSION PROTECTED

Thanks to environmentally friendly powder coating.



## COMPLETELY LOW-NOISE OPERATION

Thanks to the separate extension of the rails without crossbars.

Huni drawer cabinets offer a stable and perfectly protected solution for storing all kinds of equipment and articles. Thanks to their high-quality design and individual configuration options, these robust all-rounders are the ideal solution for all types of use and different purposes. The special design of this product ensures the highest level of purpose. In addition, cabinet bodies and drawers can be divided up in various ways, labelled intelligently, protected with access control systems and are available in virtually any colour. Nobody has ever been able to compete with such flexibility.



FULL COMPATIBILITY WITH HUNI  
PARTITION MATERIAL THANKS TO ONE  
STANDARD SIZE

see page 104

### TOTAL USE OF THE DRAWER SURFACE AREA

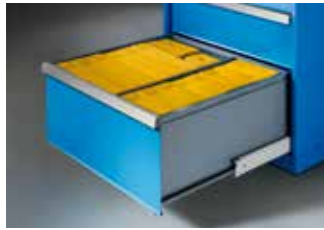

#### Optimal height of the drawer body

- Drawer rear and side panels at the same height as the drawer fronts.
- Maximum use of vertical space.
- Optimal protection against falling and loss of stored goods.



#### Full extension

- Maximum use of space for horizontal storage purposes.
- Complete overview.
- Optimum access.

### COMPLETELY LOW-NOISE OPERATION



#### Full extension without crossbar

- Smooth and completely low-noise operation thanks to full extension without crossbars.
- Allows the drawer to be fully extended.



#### Locking hooks operation

- Special plastic cover of the locking hook.
- Sliding and low-noise locking mechanism.

### PROFESSIONAL LABELLING



#### Handle prepared for inserting labels

- For simple, clear and secure labelling.



### FLEXIBLE OPTIONS FOR CUSTOMISATION



#### Cover with edges raised at different heights

- Raised edges on three sides in stationary cabinets for simple and easy cleaning.
- Cover with raised edges on four sides in castor cabinets to prevent transported goods from falling off.



#### Punch out

- Cabinet housing cover with pre-punched holes, can be freed by swinging.
- For retrofitting a worktop or a second drawer unit above it.



#### Forklift base for forklift trucks

- Base and forklift base optional (for drawer cabinets from 36 U in width).
- To simply offset the height of the drawer unit.
- Allows full cabinet to be moved with a forklift.



#### Wheeled castors

- Our castor cabinets have the following included in delivery:
  - 4-sided raised edge;
  - handle pair;
  - black ribbed mat;
  - two swivel castors with brakes;
  - two fixed castors and single drawer brake.
- You can convert the cabinet from stationary to mobile at any time.

### PARTITION MATERIAL FOR EVERY APPLICATION

#### Huni's unit of measurement

- Our partition material for drawers is adapted and therefore compatible with the entire Huni range.



Partition material for drawers, see page 104

Huni units	Depth 27 U			Depth 36 U				
	27 × 27 U	36 × 27 U	54 × 27 U	27 × 36 U	36 × 36 U	54 × 36 U	64 × 36 U	78 × 36 U
Footprint area of the cabinet mm	564 × 572	717 × 572	1023 × 572	564 × 725	717 × 725	1023 × 725	1193 × 725	1431 × 725
Usable drawer dimensions mm	459 × 459	612 × 459	918 × 459	459 × 612	612 × 612	918 × 612	1088 × 612	1326 × 612





## OPTIMUM ORDER LEVEL AND ORGANISATION

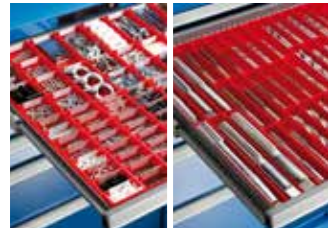

### Trays and troughs

- For small parts and cylindrical articles.



### Tool holder

- For CNC storage.



### Maximum support thanks to perforated and slotted drawers

- All-round slots in the drawer with continuous grid for the secure fixing of partition material.
- Perforated drawer base for optional fastening of slotted walls, dividers, fixing pins or milling cutter holders.



### Aluminium Dividers

- For storage of different sized articles.



### PE foam inserts

- For special tools and measurement tools.

## ADVANTAGES OF HUNI STORAGE SYSTEMS

Compared to shelf storage, storage in drawers offers the advantage that stored goods are optimally protected from dust and dirt, save valuable space and offer much better visibility. The entire contents of the drawer can be viewed in a single movement, whereas in the case of shelves, items may in some circumstances have to be moved to the side or passed over to pick up something.

### Storage in drawers

- The shelf depth can be used for different purposes depending on the stored goods, i.e. articles may be placed behind each other.
- The drawer can be pulled out for a clear view and access that does not require any more space.

#### Example of space utilisation

usable depth	4 × 600 =	2400 mm	} total 5400 mm
passage width	3 × 1000 =	3000 mm	

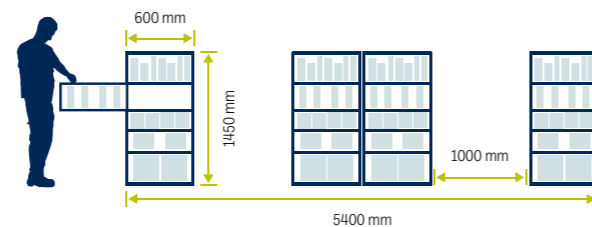

### Storage on shelves

- If the articles are smaller than the depth of the shelf, a large unusable gap is created at the back.
- If the articles are stored one behind the other, space is required to see and pick up the articles.

#### Example of space utilisation

usable depth	8 × 300 =	2400 mm	} total 6400 mm
passage width	5 × 800 =	4000 mm	

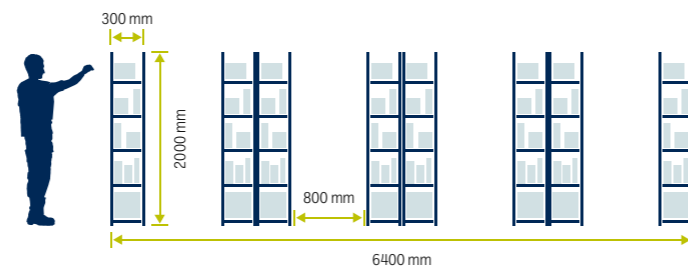

## OPTION FOR INDIVIDUAL CONFIGURATIONS

Huni drawer cabinets are available as standard, in 5 widths, 2 depths and different heights. The configuration options are virtually endless in terms of size, accessories, lock, colour and drawer partitioning. Our drawer cabinets can be individually combined to suit any work situation, making optimum use of the available space. They can be expanded at any time, making them the perfect solution for your needs, even for longer periods of use.

### Configuration examples



Configuration as a drawer cabinet.



Configuration as a drawer cabinet with internal hinged door and pull-out shelf.



Configuration as a drawer cabinet with drawers, internal hinged door and pull-out shelf.



Configuration as a mobile drawer cabinet with cover and handle pair.



ESD version on request.



## COMPLETELY SECURE



### Anti-roll bar for drawers

- Prevents the cabinet from tipping over, locking all other drawers when one is pulled out.
- Allows you to change the assembly sequence of the drawers at a later stage.



### Flush drawer front

- Drawer handles with side caps and flush lock on the front.
- Ideal solution, both visually and in terms of safety.



### Safety catch

- Meets all regulations against accidental dropping of the drawer.
- Reduces the risk of workstation accidents.
- It is easy to unlock when individual drawers are replaced.



### Capacity indication

- The load capacities (75 or 200 kg) are marked on the drawer rails.
- Enhanced security.



## EXTRA SAFETY FOR STATIONARY AND ON CASTORS



### Single safety catch right-handed

- Our standard lock for all castor cabinets.
- Can be operated with one hand.



### Double safety catch

- Double ratchet with individual ratchet features on the right.
- Increased comfort thanks to single-handed operation.



### Lilo locking device

- With external operating lever for locking the drawer in the open or closed position.
- For drawer load capacity of 200 kg.

## ENDLESS CONFIGURATION POSSIBILITIES

### Covers

Cover with 3-sided or 4-sided raised edge, floor mat, cover with resin coating, multi-layered wooden cover, handle pair (for cabinets on castors).

### Partition material

Slotted walls, partitions and separators, dividers and solid walls, troughs and troughs, milling cutter holders and fastening pins, anti-slide mats, PE foam inserts and much more.

### Locking systems

KEY Lock, CODE Lock, RFID Lock or AUTO Lock.

### Substructures

Cabinet housing base, 2-way forklift base, pairs of crossbars with castors, individual castors.

### Equipment and accessories

Drawers, pull-out shelves, adjustable shelves, hinged doors.

## 11 STANDARD COLOURS

### Wide choice of colours for maximum flexibility

All products with a choice of colours are available in 11 standard colours that can be combined at no surcharge. Cabinet bodies and drawers can be ordered in different colours. When ordering, please specify the required colour (or colour combination).



Pale blue  
RAL 5012



Pale grey  
RAL 7035



Reseda green  
RAL 6011



Ruby red  
RAL 3003



Signal Blue  
RAL 5005



Anthracite gray  
RAL 7016



Grey-white  
RAL 9002



Pebble grey  
RAL 7032



Turquoise blue  
RAL 5018



Brilliant blue  
RAL 5007



Sky blue  
RAL 5015

### Your customised colour on request

Huni can meet all your colour needs. In addition to the existing standard colours and predefined colours, the desired product can be produced on request in any colour.

! For printing reasons, there may be discrepancies between this colour chart and the original colours.

## ORDER PRECONFIGURED TEMPLATES...

Page 105

Huni units

1 Preconfigured order examples

2 Partition material

## ... OR YOU CAN CONFIGURE AND ORDER CUSTOM CABINETS

Page 105

Huni units

1 Cabinet housing

2 Drawers

3 Accessories

4 Partition material

# DRAWER CABINETS

## STATIONARY AND ON CASTORS

In addition to the stationary version, all Huni drawer units are also available with castors. This increases mobility as well as comfort and additional space. E.g. castor cabinets allow you to transport stored goods quickly and safely, but can also be easily stowed away under work surfaces when space is at a premium.



### HIGHEST LEVEL OF SAFETY AND COMFORT

Thanks to the raised perimeter edge cover, the ergonomic handle pair and the additional drawer ratchet.



### GREATER MOBILITY

Thanks to smooth-running rubber castors, depending on the floor type.



### OPTIMUM USE OF SPACE

With positioning under work surfaces.



27x27 U 459 x 459 mm W → 564 mm D ↗ 572 mm

	H ↑	Number of drawers mm	KO	Locking system	Art. no.
	300	2: 1 × 50/1 × 150	75	KEY Lock	803.1400
	300	2: 2 × 100	75	KEY Lock	803.1401
	300	3: 2 × 50/1 × 100	75	KEY Lock	803.1402
	400	2: 1 × 100/1 × 200	75	KEY Lock	803.1403
	400	3: 1 × 50/1 × 100/1 × 150	75	KEY Lock	803.1404
	400	4: 1 × 50/2 × 75/1 × 100	75	KEY Lock	803.1405
	700	6: 1 × 50/2 × 75/2 × 100/1 × 200	75	KEY Lock	803.1406
	800	4: 2 × 100/1 × 200/1 × 300	75	KEY Lock	803.1407
	800	5: 1 × 50/2 × 100/1 × 150/1 × 300	75	KEY Lock	803.1408
	850	4: 1 × 100/1 × 150/1 × 200/1 × 300	75	KEY Lock	803.1409
	850	5: 1 × 100/3 × 150/1 × 200	75	KEY Lock	803.1410
	850	6: 2 × 75/2 × 100/2 × 200	75	KEY Lock	803.1411
	850	6: 1 × 50/2 × 100/2 × 150/1 × 200	75	KEY Lock	803.1412
	850	7: 2 × 75/3 × 100/2 × 150	75	KEY Lock	803.1413
	850	8: 1 × 50/2 × 75/4 × 100/1 × 150	75	KEY Lock	803.1414
	710	4: 1 × 50/1 × 75/1 × 125/1 × 200	75	KEY Lock	803.1415
	710	5: 1 × 50/2 × 75/1 × 100/1 × 150	75	KEY Lock	803.1416
	810	6: 2 × 50/2 × 75/2 × 150	75	KEY Lock	803.1417
	860	5: 4 × 100/1 × 200	75	KEY Lock	803.1418
	860	6: 1 × 50/2 × 75/2 × 100/1 × 200	75	KEY Lock	803.1419
	860	6: 2 × 75/3 × 100/1 × 150	75	KEY Lock	803.1420

KO = drawer load capacity  
 Locking system

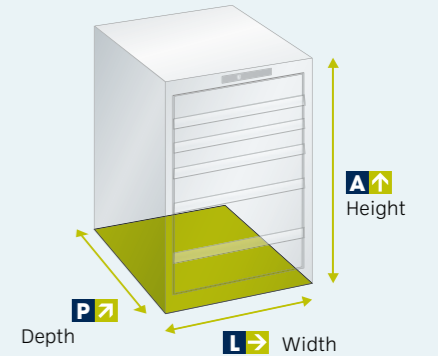

Art. no. 803.1413  
 Pale blue, RAL 5012  
 (excl. partition material)







Art. no. 803.1420  
 Pale grey, RAL 7035  
 (excl. partition material)





36x27 U 612 x 459 mm W 717 mm D 572 mm

H ↑	Number of drawers mm	Ko	Lock	Art. no.
	700 5: 1 × 50/2 × 100/1 × 150/1 × 200	75	KEY Lock	805.1400
	700 5: 2 × 75/2 × 100/1 × 250	75	KEY Lock	805.1401
	700 6: 2 × 75/3 × 100/1 × 150	75	KEY Lock	805.1402
	850 7: 1 × 50/2 × 75/2 × 100/1 × 150/1 × 200	75	KEY Lock	805.1403
	850 7: 2 × 75/2 × 100 / 2 × 125/1 × 150	75	KEY Lock	805.1404
	850 8: 4 × 75/3 × 100/1 × 150	75	KEY Lock	805.1405
	1000 7: 1 × 50/2 × 75/2 × 100/1 × 200/1 × 300	75	KEY Lock	805.1406
	1000 7: 2 × 75/1 × 100/3 × 150/1 × 200	75	KEY Lock	805.1407
	1000 8: 1 × 50/2 × 75/3 × 100/1 × 150/1 × 250	75	KEY Lock	805.1408
	860 5: 1 × 50/2 × 100/1 × 150/1 × 200	75	KEY Lock	805.1409
	860 5: 2 × 75/2 × 100/1 × 250	75	KEY Lock	805.1410
	860 6: 2 × 75/3 × 100/1 × 150	75	KEY Lock	805.1411

### Wheeled castors

All castor cabinets on this double page are equipped with:

- 1 cover with edges on 4 edges including ribbed mat;
- 1 handle pair;
- 1 pair of crossbars with rubber castors Ø 100 mm;
- individual right-hand safety catch for drawers;
- Load capacity 400 kg with evenly distributed load.

54x27 U 918 x 459 mm W 1023 mm D 572 mm

H ↑	Number of drawers mm	Ko	Lock	Art. no.
	850 5: 3 × 100/1 × 150/1 × 300**	75	KEY Lock	809.1400
	850 5: 3 × 100/1 × 150/1 × 300	200	KEY Lock	809.1401
	850 6: 2 × 75/2 × 100/1 × 150/1 × 250**	75	KEY Lock	809.1402
	850 6: 2 × 75/2 × 100/1 × 150/1 × 250	200	KEY Lock	809.1403
	850 7: 1 × 50/2 × 75/2 × 100/1 × 150/1 × 200	75	KEY Lock	809.1404
	850 7: 1 × 50/2 × 75/2 × 100/1 × 150/1 × 200	200	KEY Lock	809.1405
	1000 6: 3 × 100/2 × 150/1 × 300**	75		809.1406
	1000 6: 3 × 100/2 × 150/1 × 300	200	KEY Lock	809.1407
	1000 7: 2 × 75/1 × 100/3 × 150/1 × 200	75	KEY Lock	809.1408
	1000 7: 2 × 75/1 × 100/3 × 150/1 × 200	200	KEY Lock	809.1409
	1000 8: 2 × 75/4 × 100/1 × 150 / 1 × 200	75	KEY Lock	809.1410
	1000 8: 2 × 75/4 × 100/1 × 150 / 1 × 200	200	KEY Lock	809.1411
	1450 9: 2 × 75/2 × 100/2 × 150/2 × 200/1 × 300**	75	KEY Lock	809.1412
	1450 9: 2 × 75/2 × 100/2 × 150/2 × 200/1 × 300	200	KEY Lock	809.1413
	1450 10: 2 × 75/3 × 100/2 × 150/3 × 200	75	KEY Lock	809.1414
	1450 10: 2 × 75/3 × 100/2 × 150/3 × 200	200	KEY Lock	809.1415
	1450 11: 2 × 75/5 × 100/2 × 150/2 × 200	75	KEY Lock	809.1416
	1450 11: 2 × 75/5 × 100/2 × 150/2 × 200	200	KEY Lock	809.1417
	860 4: 1 × 100/2 × 150/1 × 200	75	KEY Lock	809.1418
	860 5: 2 × 75/1 × 100/1 × 150/1 × 200	75	KEY Lock	809.1419
	860 6: 2 × 75/3 × 100/1 × 150	75	KEY Lock	809.1420

\* Maximum load 75 kg.  
\*\* Load capacity 200 kg.



Art. no. 805.1400  
Cabinet housing: turquoise blue, RAL 5018  
Drawers: pale grey, RAL 7035  
(excl. partition material)



Art. no. 805.1410  
Reseda green, RAL 6011  
(excl. partition material)



Art. no. 809.1420  
Pale blue, RAL 5012  
(excl. partition material)



Art. no. 809.1414  
Pale grey, RAL 7035  
(excl. partition material)





**27x36 U** 459 x 612 mm **W** 564 mm **D** 725 mm

	<b>H</b> ↑	Number of drawers mm	<b>K</b> ↓	<b>L</b> ↓	Art. no.
	300	2: 1 × 50/1 × 150	75	KEY Lock	804.1400
	300	2: 2 × 100	75	KEY Lock	804.1401
	400	3: 1 × 50/1 × 100/1 × 150	75	KEY Lock	804.1402
	400	3: 2 × 75/1 × 150	75	KEY Lock	804.1403
	550	4: 1 × 50/2 × 100/1 × 200	75	KEY Lock	804.1404
	550	5: 1 × 50/2 × 75/1 × 100/1 × 150	75	KEY Lock	804.1405
	700	5: 2 × 75/1 × 100/1 × 150/1 × 200	75	KEY Lock	804.1406
	700	4: 1 × 100/2 × 150/1 × 200	75	KEY Lock	804.1407
	700	6: 1 × 50/2 × 75/2 × 100/1 × 200	75	KEY Lock	804.1408
	800	4: 2 × 100/1 × 200/1 × 300	75	KEY Lock	804.1409
	800	5: 1 × 50/2 × 100/1 × 150/1 × 300	75	KEY Lock	804.1410
	800	6: 2 × 75/2 × 100/1 × 150/1 × 200	75	KEY Lock	804.1411
	800	7: 1 × 50/2 × 75/2 × 100/2 × 150	75	KEY Lock	804.1412
	800	7: 2 × 75/4 × 100/1 × 150	75	KEY Lock	804.1413
	800	1: 1 × 100 + 1 door 600, right/ 1 adjustable shelf/1 pull-out shelf	75	KEY Lock	804.1414
	850	4: 3 × 150/1 × 300	75	KEY Lock	804.1415
	850	5: 1 × 50/2 × 100/1 × 200/1 × 300	75	KEY Lock	804.1416
	850	6: 1 × 75/3 × 100/1 × 125/1 × 250	75	KEY Lock	804.1417
	850	5: 2 × 100/1 × 150/2 × 200	75	KEY Lock	804.1418
	850	6: 1 × 50/2 × 100/2 × 150/1 × 200	75	KEY Lock	804.1419
	850	7: 1 × 50/2 × 75/2 × 100/1 × 150/1 × 200	75	KEY Lock	804.1420
	850	7: 2 × 75/3 × 100/2 × 150	75	KEY Lock	804.1421
	850	8: 1 × 50/2 × 75/4 × 100/1 × 150	75	KEY Lock	804.1422



Art. no. **804.1413**  
Cabinet housing: pale grey, RAL 7035  
Drawers: ruby red, RAL 3003  
(excl. partition material)

### Wheeled castors

All castor cabinets on this double page are equipped with:

- 1 cover with 3-sided edging incl. ribbed mat;
- 1 handle pair;
- 1 pair of crossbars with rubber castors Ø 100 mm;
- individual right-hand ratchet for drawers;
- Load capacity 400 kg with evenly distributed load.

**27x36 U** 459 x 612 mm **W** 564 mm **D** 725 mm

	<b>H</b> ↑	Number of drawers mm	<b>K</b> ↓	<b>L</b> ↓	Art. no.
	710	4: 1 × 50/2 × 100/1 × 200	75	KEY Lock	804.1423
	710	5: 2 × 50/2 × 100/1 × 150	75	KEY Lock	804.1424
	710	6: 2 × 50/2 × 75/2 × 100	75	KEY Lock	804.1425
	860	5: 2 × 75/1 × 100/1 × 150/1 × 200	75	KEY Lock	804.1426
	860	6: 1 × 50/2 × 75/2 × 100/1 × 200	75	KEY Lock	804.1427
	960	5: 1 × 50/2 × 100/1 × 150/1 × 300	75	KEY Lock	804.1428
	960	5: 3 × 100/2 × 200	75	KEY Lock	804.1429
	960	7: 1 × 50/2 × 75/2 × 100/2 × 150	75	KEY Lock	804.1430
	960	7: 2 × 75/4 × 100/1 × 150	75	KEY Lock	804.1431
	760	3: 1 × 50/1 × 100/1 × 150	75	KEY Lock	804.511
	760	1 adjustable shelf	75	-	822.066

Name	<b>H</b> ↑	<b>W</b> →	<b>D</b> ↗	Art. no.
Frame with castors (2 fixed castors, 2 swivel castors with brakes)	760	573	733	822.191
Top shelf with ribbed rubber mat	25	567	727	822.082
Mezzanine floor	25	567	727	822.081
Push handle	-	57	-	822.116



Art. no. **804.1320**  
Cabinet housing: pale grey, RAL 7035  
Drawers: ruby red, RAL 3003  
(excl. partition material)



Art. no. **804.1414**  
Cabinet body: ruby red, RAL 3003  
Drawers: grey-white, RAL 9002  
(excl. partition material)

### Equipment with drawers and doors

The cabinet housings can be optionally equipped with drawers and a single-leaf door. If a door leaf is fixed inside the cabinet, pull-out shelves must be used for this purpose. Both locks are standard with the same numbering. An identical number lock or a lock with CODE/RFID lock is available on request (CODE/RFID Lock not available for door leaves).





36x36 U 612 x 612 mm W 717 mm D 725 mm

H ↑	Number of drawers mm	KG	Lock	Art. no.
800	4: 1 × 100/2 × 150/1 × 300	75	KEY Lock	806.1400
800	6: 2 × 75/2 × 100/1 × 150/1 × 200	75	KEY Lock	806.1401
850	4: 1 × 100/1 × 150/1 × 200/1 × 300	75	KEY Lock	806.1402
850	4: 1 × 100/1 × 150/1 × 200/1 × 300	200	KEY Lock	806.1403
850	5: 1 × 50/2 × 100/1 × 200/1 × 300	75	KEY Lock	806.1404
850	5: 1 × 50/2 × 100/1 × 200/1 × 300	200	KEY Lock	806.1405
850	5: 1 × 100/3 × 150/1 × 200	75	KEY Lock	806.1406
850	5: 1 × 100/3 × 150/1 × 200	200	KEY Lock	806.1407
850	7: 1 × 50/2 × 75/2 × 100/1 × 150/1 × 200	75	KEY Lock	806.1408
850	7: 1 × 50/2 × 75/2 × 100/1 × 150/1 × 200	200	KEY Lock	806.1409
850	7: 2 × 75/3 × 100/2 × 150	75	KEY Lock	806.1410
850	7: 2 × 75/3 × 100/2 × 150	200	KEY Lock	806.1411
850	8: 1 × 50/2 × 75/4 × 100/1 × 150	75	KEY Lock	806.1412
850	8: 1 × 50/2 × 75/4 × 100/1 × 150	200	KEY Lock	806.1413

\* Maximum load 75 kg.

### Wheeled castors

All castor cabinets on this double page are equipped with:

- 1 cover with 3-sided edging incl. ribbed mat;
- 1 handle pair;
- 1 pair of crossbars with rubber castors Ø 100 mm;
- individual right-hand safety catch for drawers;
- Load capacity 400 kg with evenly distributed load.



Art. no. 806.1405  
Cabinet housing: pale grey, RAL 7035  
Drawers: pale blue, RAL 5012  
(excl. partition material)

36x36 U 612 x 612 mm W 717 mm D 725 mm

H ↑	Number of drawers mm	KG	Lock	Art. no.
1000	6: 1 × 50/3 × 150/2 × 200	75	KEY Lock	806.1414
1000	6: 1 × 50/3 × 150/2 × 200	200	KEY Lock	806.1415
1000	6: 1 × 100/4 × 150/1 × 200	75	KEY Lock	806.1416
1000	6: 1 × 100/4 × 150/1 × 200	200	KEY Lock	806.1417
1000	7: 1 × 50/2 × 75/2 × 100/1 × 200/1 × 300	75	KEY Lock	806.1418
1000	7: 1 × 50/2 × 75/2 × 100/1 × 200/1 × 300	200	KEY Lock	806.1419
1000	8: 1 × 50/2 × 75/2 × 100/2 × 150/1 × 200	75	KEY Lock	806.1420
1000	8: 1 × 50/2 × 75/2 × 100/2 × 150/1 × 200	200	KEY Lock	806.1421
1000	8: 2 × 75/3 × 100/3 × 150	75	KEY Lock	806.1422
1000	8: 2 × 75/3 × 100/3 × 150	200	KEY Lock	806.1423
1000	9: 9 × 100	75	KEY Lock	806.1424
1000	9: 9 × 100	200	KEY Lock	806.1425
1000	10: 1 × 50/2 × 75/7 × 100	75	KEY Lock	806.1426
1000	10: 1 × 50/2 × 75/7 × 100	200	KEY Lock	806.1427
1450	9: 2 × 75/2 × 100/2 × 150/2 × 200/1 × 300	75	KEY Lock	806.1428
1450	9: 2 × 75/2 × 100/2 × 150/2 × 200/1 × 300	200	KEY Lock	806.1429
1450	9: 3 × 100/5 × 150/1 × 300	75	KEY Lock	806.1430
1450	9: 3 × 100/5 × 150/1 × 300	200	KEY Lock	806.1431
1450	10: 1 × 50/5 × 100/4 × 200	75	KEY Lock	806.1432
1450	10: 1 × 50/5 × 100/4 × 200	200	KEY Lock	806.1433
860	3: 1 × 100/1 × 200/1 × 300	200	KEY Lock	806.1434
860	5: 1 × 50/2 × 100/1 × 150/1 × 200	75	KEY Lock	806.1435
860	6: 2 × 75/3 × 100/1 × 150	75	KEY Lock	806.1436
860	5: 1 × 50/2 × 100/1 × 150/1 × 200	75	KEY Lock	806.1437
1010	7: 2 × 75/2 × 100/2 × 125/1 × 150	75	KEY Lock	806.1438
1010	8: 4 × 75/3 × 100/1 × 150	75	KEY Lock	806.1439

\* Maximum load 75 kg.



Art. no. 806.1431  
Anthracite gray, RAL 7016  
(excl. partition material)



Art. no. 806.1439  
Sky blue, RAL 5015  
(excl. partition material)



Art. no. 806.1419  
Pale blue, RAL 5012  
(excl. partition material)





54x36 U 918 x 612 mm W 1023 mm D 725 mm

H ↑	Number of drawers mm	KG	Lock	Art. no.
850	5: 3 × 100/1 × 150/1 × 300**	75	KEY Lock	810.1400
850	5: 3 × 100/1 × 150/1 × 300	200	KEY Lock	810.1401
850	6: 2 × 75/2 × 100/1 × 150/1 × 250**	75	KEY Lock	810.1402
850	6: 2 × 75/2 × 100/1 × 150/1 × 250	200	KEY Lock	810.1403
850	7: 1 × 50/2 × 75/2 × 100/1 × 150/1 × 200	75	KEY Lock	810.1404
850	7: 1 × 50/2 × 75/2 × 100/1 × 150/1 × 200	200	KEY Lock	810.1405
1000	5: 2 × 100/2 × 200/1 × 300**	75	KEY Lock	810.1406
1000	5: 2 × 100/2 × 200/1 × 300	200	KEY Lock	810.1407
1000	6: 1 × 100/4 × 150/1 × 200	75	KEY Lock	810.1408
1000	6: 1 × 100/4 × 150/1 × 200	200	KEY Lock	810.1409
1000	7: 1 × 50/2 × 75/2 × 100/1 × 200/1 × 300**	75	KEY Lock	810.1410
1000	7: 1 × 50/2 × 75/2 × 100/1 × 200/1 × 300	200	KEY Lock	810.1411
1000	8: 1 × 50/2 × 75/2 × 100/2 × 150/1 × 200	75	KEY Lock	810.1412
1000	8: 1 × 50/2 × 75/2 × 100/2 × 150/1 × 200	200	KEY Lock	810.1413
1000	8: 2 × 75/3 × 100/3 × 150	75	KEY Lock	810.1414
1000	8: 2 × 75/3 × 100/3 × 150	200	KEY Lock	810.1415
1000	10: 1 × 50/2 × 75/7 × 100	75	KEY Lock	810.1416
1000	10: 1 × 50/2 × 75/7 × 100	200	KEY Lock	810.1417
1450	9: 2 × 75/2 × 100/2 × 150/2 × 200/1 × 300**	75	KEY Lock	810.1418
1450	9: 2 × 75/2 × 100/2 × 150/2 × 200/1 × 300	200	KEY Lock	810.1419
1450	9: 3 × 100/5 × 150/1 × 300**	75	KEY Lock	810.1420
1450	9: 3 × 100/5 × 150/1 × 300	200	KEY Lock	810.1421
1450	10: 1 × 50/5 × 100/4 × 200	75	KEY Lock	810.1422
1450	10: 1 × 50/5 × 100/4 × 200	200	KEY Lock	810.1423



\* Maximum load 75 kg.  
\*\* Load capacity 200 kg.



Art. no. 810.1411  
Cabinet housing: pale grey, RAL 7035  
Drawers: pale blue, RAL 5012  
(excl. partition material)



Art. no. 810.1420  
Brilliant blue, RAL 5007  
(excl. partition material)

64x36 U 1088 x 612 mm W 1193 mm D 725 mm

H ↑	Number of drawers mm	KG	Lock	Art. no.
1000	7: 2 × 75/2 × 100/1 × 150/2 × 200**	75	KEY Lock	812.1400
1000	7: 2 × 75/2 × 100/1 × 150/2 × 200	200	KEY Lock	812.1401
1000	8: 2 × 75/4 × 100/1 × 150/1 × 200**	75	KEY Lock	812.1402
1000	8: 2 × 75/4 × 100/1 × 150/1 × 200	200	KEY Lock	812.1403
1000	8: 2 × 75/3 × 100/3 × 150**	75	KEY Lock	812.1404
1000	8: 2 × 75/3 × 100/3 × 150	200	KEY Lock	812.1405
1450	10: 2 × 150/1 × 125/1 × 75/3 × 100/1 × 150/2 × 200	200	KEY Lock	812.1406
1450	11: 1 × 150/1 × 125/1 × 75/5 × 100/2 × 150/1 × 200	200	KEY Lock	812.1407
1450	12: 1 × 150/1 × 125/3 × 75/5 × 100/1 × 150/1 × 200	200	KEY Lock	812.1408



\*\* Load capacity 200 kg.



Art. no. 812.1408  
Cabinet body: pebble grey, RAL 7032  
Fronts: pale blue, RAL 5012  
(excl. partition material)

78x36 U 1326 x 612 mm W 1431 mm D 725 mm

H ↑	Number of drawers mm	KG	Lock	Art. no.
1000	5: 2 × 100/2 × 200/1 × 300	200	KEY Lock	814.1401
1000	7: 2 × 75/2 × 100/1 × 150/2 × 200	200	KEY Lock	814.1403
1000	8: 2 × 75/4 × 100/1 × 150/1 × 200	200	KEY Lock	814.1405
1450	10: 2 × 150/1 × 125/1 × 75/3 × 100/1 × 150/2 × 200	200	KEY Lock	814.1406
1450	11: 1 × 150/1 × 125/1 × 75/5 × 100/2 × 150/1 × 200	200	KEY Lock	814.1407
1450	12: 1 × 150/1 × 125/3 × 75/5 × 100/1 × 150/1 × 200	200	KEY Lock	814.1408



Art. no. 814.1406  
Cabinet housing: pale grey, RAL 7035  
Fronts: ruby red, RAL 3003  
(excl. partition material)



## 1 Cabinet housing with locking systems

The cabinet body can be individually configured with KEY Lock, CODE Lock, RFID Lock or AUTO Lock locking systems to lock all drawers at the same time.

Depth 27 U		
27 x 27 U	36 x 27 U	54 x 27 U



W → × D ↗	564 × 572 mm	717 × 572 mm	1023 × 572 mm
Clear height	Art. no.	Art. no.	Art. no.
300	200	803.005	-
400	300	803.009	-
550	450	803.015	805.015
650	550	803.019	-
700	600	803.021	805.021
800	700	803.025	-
850	750	803.027	805.027
1000	900	803.033	805.033
1150	1050	-	-
1325	1225	-	-
1450	1350	-	805.051
1625	1525	-	-

Depth 36 U				
27 x 36 U	36 x 36 U	54 x 36 U	64 x 36 U	78 x 36 U



564 × 725 mm	717 × 725 mm	1023 × 725 mm	1193 × 725 mm	1431 × 725 mm
Art. no.	Art. no.	Art. no.	Art. no.	Art. no.
804.005	-	-	-	-
804.009	-	-	-	-
804.015	-	-	-	-
804.019	-	-	-	-
804.021	806.021	810.021	812.021	-
804.025	806.025	-	-	-
804.027	806.027	810.027	812.027	-
804.033	806.033	810.033	812.033	814.033
-	806.039	810.039	-	-
-	806.046	810.046	812.046	814.046
-	806.051	810.051	812.051	814.051
-	806.058	-	-	-



Cabinet housing  
This double page.

1

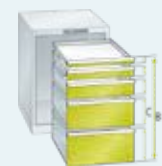

Drawers  
See pages 38-39

2



Accessories  
See pages 40-43.

3



Partition material  
See pages 104-121

4

The new generation of Huni locking systems combines maximum security with extreme flexibility. The different systems can be freely combined to create a locking option that perfectly suits you and your needs. We would be happy to advise you.



### KEY LOCK

The tried-and-tested standard lock.  
KEY Lock code: **820.002**



### CODE LOCK

The modern solution with number combination.  
CODE Lock code: **820.011**



### RFID LOCK

The ideal solution for the future: the RFID badge option.  
RFID Lock code: **820.060**



### AUTO LOCK

The ultimate solution: automatic opening and locking with RFID badges.  
AUTO Lock code: **820.066**

For colour information, see fold-out page. When ordering, please specify the required colour (or colour combination).





**2 Drawers**

Drawers with different front heights can be installed in the cabinet housing in any preferred order. The perimeter walls of the drawer are fitted with a 17 mm grid (U) for individual subdivision. The capacities given below apply to capacities with an evenly distributed load.

				Depth 27 U		
				27 x 27 U	36 x 27 U	54 x 27 U
<b>W</b> → × <b>D</b> ↗	459 × 459 mm	612 × 459 mm	918 × 459 mm			
<b>H</b> ↑	Clear height	H. body drawer	Art. no.	Art. no.	Art. no.	
50*	32	31	803.101	805.101	809.101	
75	57	49	803.102	805.102	809.102	
100	82	77	803.103	805.103	809.103	
125	107	77	803.104	805.104	809.104	
150	132	127	803.105	805.105	809.105	
200	182	177	803.107	805.107	809.107	
250	232	227	803.109	805.109	809.109	
300	282	277	803.111	805.111	809.111	
400	382	277	-	-	-	
450	432	277	-	-	-	

				459 × 459 mm	612 × 459 mm	918 × 459 mm
<b>W</b> → × <b>D</b> ↗	459 × 459 mm	612 × 459 mm	918 × 459 mm			
<b>H</b> ↑	Clear height	H. body drawer	Art. no.	Art. no.	Art. no.	
75	57	31	803.127	805.127	809.127	
100	82	77	803.128	805.128	809.128	
125	107	77	803.129	805.129	809.129	
150	132	127	803.130	805.130	809.130	
200	182	177	803.132	805.132	809.132	
250	232	227	803.134	805.134	809.134	
300	282	277	803.136	805.136	809.136	
400	382	277	-	-	-	
450	432	277	-	-	-	

\*Drawers with 50 mm front height must be placed at the top.

					Depth 36 U				
					27 x 36 U	36 x 36 U	54 x 36 U	64 x 36 U	78 x 36 U
					459 × 612 mm	612 × 612 mm	918 × 612 mm	1088 × 612 mm	1326 × 612 mm
					Art. no.	Art. no.	Art. no.	Art. no.	Art. no.
					804.101	806.101	810.101	-	-
					804.102	806.102	810.102	812.102	-
					804.103	806.103	810.103	812.103	-
					804.104	806.104	810.104	-	-
					804.105	806.105	810.105	-	-
					804.107	806.107	810.107	-	-
					804.109	806.109	810.109	-	-
					804.111	806.111	810.111	-	-
					-	806.115	810.115	-	-
					-	806.117	-	-	-

					459 × 612 mm	612 × 612 mm	918 × 612 mm	1088 × 612 mm	1326 × 612 mm
					Art. no.	Art. no.	Art. no.	Art. no.	Art. no.
					804.127	806.127	810.127	812.127	814.127
					804.128	806.128	810.128	812.128	814.128
					804.129	806.129	810.129	812.129	814.129
					804.130	806.130	810.130	812.130	814.130
					804.132	806.132	810.132	812.132	814.132
					804.134	806.134	810.134	812.134	814.134
					804.136	806.136	810.136	812.136	814.136
					-	806.140	810.140	-	-
					-	806.142	810.142	-	-

**Drawer safety catch (art. no. 828.270)**

**Standard**  
Standard version including individual drawer locks (all article numbers are shown in the table).

**Individual safety catch on the right**  
THIS IS a prerequisite for trolleys on castors. The individual drawer latch on the right can be unlocked with one hand and prevents the drawers from being unintentionally opened even when the cabinet is not closed.

**Cardboard + cellux set (10 pcs each)**

- 36E - 828.266
- 54E - 828.267
- 27E - 828.265
- 78E - 828.268
- 64E - 828.269

**Order notes**

The usable height of the cabinet body is essential when selecting drawers. The sum of the front heights (C) must correspond to the clear height (B) (see diagram).

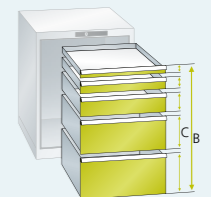

For colour information, see fold-out page. When ordering, please specify the required colour (or colour combination).

### 3 Accessories

The following accessories are also available on request:



#### Hinged doors attached on the inside for pull-out shelves and adjustable shelves

Made of sheet steel, as front cover for pull-out and adjustable shelves countersunk into the cabinet housing under the drawers. With handle incl. KEY Lock. The sum of the front height of the hinged door and all drawer front heights must correspond to the cabinet housing height.

		Depth 27 U	
		27 x 27 U	36 x 27 U
<b>Hinged door, internal*</b>		<b>Art. no.</b>	<b>Art. no.</b>
Mounted on the right	H 400 mm	821.009	-
Mounted on the right	H 450 mm	821.013	-
Mounted on the right	H 550 mm	821.021	-
Mounted on the right	H 600 mm	821.025	-
Left-side hinge	H 400 mm	821.010	-
Left-side hinge	H 450 mm	821.014	-
Left-side hinge	H 550 mm	821.022	-
Left-side hinge	H 600 mm	821.026	-

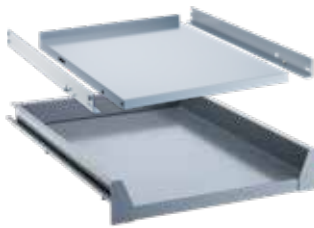

#### Pull-out shelves and adjustable shelves for internal doors

Made of sheet steel, can be painted according to colour chart. Load capacity of pull-out shelves 75 kg, adjustable shelves 200 kg. Thanks to the 25 mm grid in the vertical side frames of the cabinet housing, the shelves can be placed in the cabinet housing in the desired sequence.

		Depth 27 U	
		27 x 27 U	36 x 27 U
<b>Adjustable shelf</b>		<b>Art. no.</b>	<b>Art. no.</b>
Usable dimensions (W x D mm)		803.155 507 x 466	805.155 660 x 466
<b>Pull-out shelf</b>		<b>Art. no.</b>	<b>Art. no.</b>
Usable dimensions (W x D mm)		803.153 434 x 459	-



#### Cover with 3-sided edge and ribbed mat

Made of sheet steel, black, RAL 9005, including black ribbed floor mat.

		Depth 27 U	
		27 x 27 U	36 x 27 U
<b>Raised edge with ribbed mat</b>		<b>Art. no.</b>	<b>Art. no.</b>
Usable dimensions (W x D x H mm)		803.156 564 x 572 x 20	805.156 717 x 572 x 20
<b>Ribbed mat, single</b>		<b>Art. no.</b>	<b>Art. no.</b>
Usable dimensions (W x D x H mm)		803.157 559 x 567 x 3	805.157 712 x 567 x 3



#### Cover with resin coating

Surface and edges in pale grey, NCS S 1500-N, decorative chipboard panel (quality grade E1), with melamine coating on both sides (made in accordance with EN 14322). All sides with sturdy 2 mm plastic edges. Incl. drilled holes and fastening material.

		Depth 27 U	
		27 x 27 U	36 x 27 U
<b>Resin cover</b>		<b>Art. no.</b>	<b>Art. no.</b>
Usable dimensions (W x D x H mm)		827.355 564 x 572 x 22	827.356 717 x 572 x 22



#### Multi-layer cover

Made of steam-impregnated beech veneer, glued in multiple layers, waterproof (DIN 68,705), chamfered corners, smoothed, oiled and waxed area. The top is splash-proof, dirt-repellent and completely resistant to oil and grease. Incl. drilled holes and fastening material.

		Depth 27 U	
		27 x 27 U	36 x 27 U
<b>Multi-layer cover</b>		<b>Art. no.</b>	<b>Art. no.</b>
Usable dimensions (W x D x H mm)		827.089 564 x 572 x 20	827.090 717 x 572 x 20

Depth 27 U
54 x 27 U
<b>Art. no.</b>
-
-
-
-
-
-
-
-
-

<b>Art. no.</b>
809.155
-

<b>Art. no.</b>
809.156 1023 x 572 x 20
809.157 1018 x 567 x 3

<b>Art. no.</b>
827.357 1023 x 572 x 22

<b>Art. no.</b>
827.034 1023 x 572 x 22

Depth 36 U				
27 x 36 U	36 x 36 U	54 x 36 U	64 x 36 U	78 x 36 U
<b>Art. no.</b>	<b>Art. no.</b>	<b>Art. no.</b>	<b>Art. no.</b>	<b>Art. no.</b>
821.009	-	-	-	-
821.013	-	-	-	-
821.021	-	-	-	-
821.025	-	-	-	-
821.010	-	-	-	-
821.014	-	-	-	-
821.022	-	-	-	-
821.026	-	-	-	-

<b>Art. no.</b>	<b>Art. no.</b>	<b>Art. no.</b>	<b>Art. no.</b>	<b>Art. no.</b>
804.155 507 x 619	806.155 660 x 619	812.155	-	814.155
804.153 434 x 612	806.153 587 x 612	-	-	-

<b>Art. no.</b>	<b>Art. no.</b>	<b>Art. no.</b>	<b>Art. no.</b>	<b>Art. no.</b>
804.156 564 x 725 x 20	806.156 717 x 725 x 20	810.156 1023 x 725 x 20	812.156 1193 x 725 x 20	814.156 1431 x 725 x 20
804.157 559 x 720 x 3	806.157 712 x 720 x 3	810.157 1018 x 720 x 3	812.157 1188 x 720 x 3	814.157 1462 x 720 x 3

<b>Art. no.</b>	<b>Art. no.</b>	<b>Art. no.</b>	<b>Art. no.</b>	<b>Art. no.</b>
827.358 564 x 725 x 22	827.359 717 x 725 x 22	827.360 1023 x 725 x 22	827.361 1193 x 725 x 22	827.362 1431 x 725 x 22

<b>Art. no.</b>	<b>Art. no.</b>	<b>Art. no.</b>	<b>Art. no.</b>	<b>Art. no.</b>
827.036 564 x 725 x 22	827.040 717 x 725 x 22	827.048 1023 x 725 x 22	827.042 1193 x 725 x 22	827.043 1431 x 725 x 22





**Cabinet base**

Made of sheet steel, for height compensation, can be painted according to colour chart.

**Cabinet base, 50 mm**  
Usable dimensions (W × D mm)

Depth 27 U	
27 × 27 U	36 × 27 U
Art. no.	Art. no.
803.161	805.161
564 × 540	717 × 540
<b>Cabinet base, h 100 mm</b> Usable dimensions (W × D mm)	-
803.164	-
564 × 540	-



**2-way forklift base for forklift trucks**

Made of sheet steel, to be screwed to the base of the cabinet, can be painted according to colour chart.

**Base, h 100 mm**  
Usable dimensions (W × D mm)

Depth 27 U	
27 × 27 U	36 × 27 U
Art. no.	Art. no.
803.161	805.161
564 × 540	717 × 540
<b>Cabinet base, h 100 mm</b> Usable dimensions (W × D mm)	-
803.164	-
564 × 540	-
<b>Base, h 100 mm</b> Usable dimensions (W × D mm)	805.174
-	715 × 542



**4-sided raised edge**

Made of sheet steel, RAL 9005 including ribbed mat, black.

**Cover with edge, h 53 mm**  
Usable dimensions (W × D mm)

Depth 27 U	
27 × 27 U	36 × 27 U
Art. no.	Art. no.
803.158	805.158
564 × 572	717 × 572



**Pairs of crossbars with castors**

Set consisting of 2 swivel castors with brakes and 2 fixed castors. Stand with galvanised castors. Grey rubber castors.

**With rubber castors, ø 100 mm**  
H/load capacity kg  
Direction of travel

Depth 27 U	
27 × 27 U	36 × 27 U
Art. no.	Art. no.
822.159	822.175
137/400	137/400
longitudinal	transverse



For safety reasons, trolleys on castors must be equipped with individual ratchets for the drawers.

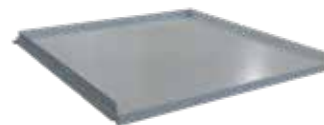

**Adjustable shelves**

Made of sheet steel, powder coating according to colour chart. Can be inserted into the drawer unit at any height. Fastening material included. Load capacity 80 kg.

**Shelves, h 75 mm**  
Usable dimensions (W × D mm)

Depth 27 U	
27 × 27 U	36 × 27 U
Art. no.	Art. no.
803.155	805.155
509 × 472	662 × 472



**Telescopic pull-out shelves**

Made of sheet steel, powder coating according to colour chart. The shelves with fully extendable telescopic rails can be countersunk at any height. Capacity with an evenly distributed load

**Load capacity 75 kg, at 75 mm**  
**Load capacity 200 kg, H 75 mm**  
Usable dimensions (W × D mm)

Depth 27 U	
27 × 27 U	36 × 27 U
Art. no.	Art. no.
809.151	805.151
809.152	805.152
918 × 459	-



**Handle pair**

Suitable for all cabinet depths. Art. no. 822.118.

Depth 27 U	
27 × 27 U	36 × 27 U
Art. no.	Art. no.
809.161	805.161
1023 × 540	717 × 540
-	-
809.174	805.174
1021 × 542	715 × 542
809.158	805.158
1023 × 572	717 × 572
822.175	822.175
137/400	137/400
transverse	transverse
809.155	805.155
968 × 472	662 × 472
809.151	805.151
809.152	805.152
918 × 459	-

Depth 36 U				
27 × 36 U	36 × 36 U	54 × 36 U	64 × 36 U	78 × 36 U
Art. no.	Art. no.	Art. no.	Art. no.	Art. no.
804.161	806.161	810.161	812.161	814.161
564 × 693	717 × 693	1023 × 693	1193 × 693	1431 × 693
804.164	-	-	-	-
564 × 693	-	-	-	-

-	806.174	810.174	812.174	814.174
-	715 × 695	1021 × 695	1191 × 695	1429 × 695

804.158	806.158	810.158	812.158	814.158
564 × 725	717 × 725	1023 × 725	1193 × 725	1731 × 725

822.181	822.181	822.182	822.182	822.182
137/400	137/400	137/400	137/400	137/400
longitudinal	longitudinal/transverse	transverse	transverse	transverse

804.155	806.155	810.155	812.155	814.155
509 × 625	662 × 625	968 × 625	1138 × 625	1376 × 625

804.151	806.151	810.151	-	-
-	806.152	810.152	812.152	814.152
-	612 × 612	918 × 612	1088 × 612	1326 × 612



# DRAWER CABINETS ELECTRIFIED DRAWERS

Electrified drawers are the solution for centrally charging batteries and electronic devices. All cabinets can be individually configured and adapted to individual storage requirements thanks to the flexible integration of cabinet accessories, partition material and power supply using power supply modules.



## FLEXIBLE APPLICATION OPTIONS

With charging systems for battery-powered electrical devices, devices for operational data acquisition, notebooks, tablets and smartphones.



## PERFECT CABLE MANAGEMENT

Thanks to cable openings for safe and tidy cable routing.



## GREAT DESIGN DIVERSITY

With sockets, ON/OFF switch, Power USB.



## COMPLETELY SECURE

CE compliant.



## 1 Cabinet housing

Body incl. cable gland for power supply, with wiring, excl. earth connection cable (must be ordered separately depending on the lower version). For simultaneous locking of all drawers. Incl. KEY Lock, our standard locking system with exchangeable cylinder. Manual locking/unlocking using a key.



Footprint area of the cabinet mm W → × D ↗	36 × 36 U		54 × 36 U	
	717 × 725 mm		1023 × 725 mm	
H ↑ Clear height	Art. no.		Art. no.	
700	600		806.1301	810.1301
850	750		806.1302	810.1302
1000	900		806.1303	810.1303
1150	1050		806.1304	810.1304
1450	1350		806.1305	810.1305



Cabinet accessories see from page 40



For partition material, see page 104

## 2 Drawers

Drawers with different front heights can be installed in the cabinet housing in any preferred order. The perimeter walls of the drawer are fitted with a 17 mm grid (U) for individual subdivision.

### Ordering notes

The usable height of the cabinet body is essential when selecting drawers. The sum of the front heights (C) must correspond to the clear height (B) (see diagram).

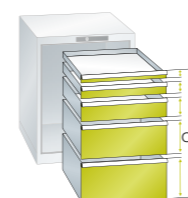

Usable dimensions of drawers mm W → × D ↗	36 × 36 U		54 × 36 U			
	717 × 725 mm		1023 × 725 mm			
Drawer load capacity	75 kg	200 kg	75 kg	200 kg		
H ↑ Clear height	H. body drawer	Art. no.	Art. no.	Art. no.	Art. no.	
<b>"Standard" drawers without power supply</b>						
50*	32.5	28.5	806.101	-	810.101	-
75	57.5	49	806.102	806.127	810.102	810.127
100	82.5	76	806.103	806.128	810.103	810.128
125	107.5	76	806.104	806.129	810.104	810.129
150	132.5	126	806.105	806.130	810.105	810.130
200	182.5	176	806.107	806.132	810.107	810.132
250	232.5	226	806.109	806.134	810.109	810.134
300	282.5	276	806.111	806.136	810.111	810.136
<b>Drawers with power supply</b>						
With hole for inserting 1 × power supply module, incl. cable routing, excl. connection cable (to be ordered separately according to the article numbers below).						
200	182.5	176	-	806.1306	-	810.1306
250	232.5	226	-	806.1307	-	810.1307
300	282.5	276	-	806.1308	-	810.1308



Max. 3 electric drawers per cabinet

\*Drawers with 50 mm front height can NOT be placed under 200 Kg load capacity drawers

## 3 Drawers

Power modules for electric drawers.



Power supply module  
D/PE, art. no. 830.1320

Mains power cable  
Incl. grounding, length 3 m, art. no. 830.1311 (PE), 830.1312 (CH), 830.1313 (UK)



\* The connection cable incl. earth connection must be used.



For colour information, see fold-out page. When ordering, please specify the required colour (or colour combination).

# DRAWER CABINETS

## HINGED/SLIDING DOORS

Huni drawer cabinets with hinged or sliding doors are ideal for large and heavy stored goods. Thanks to the doors, even tall objects can be securely closed, effectively protecting them from dirt, damage and unwanted access. Flexible internal partitions and different locking systems ensure you can find the optimal solution for every requirement - of course, with countless clever details and a 10-year guarantee. You wouldn't expect anything less from Huni.



### IDEAL FOR LARGE STORED GOODS WITH A WEIGHT OF UP TO 200 KG/DRAWER

With pull-out shelves for storage flush with the storage area.



### ALWAYS ADAPTABLE TO NEWLY STORED GOODS

Thanks to the flexibility of installing and repositioning drawers, pull-out shelves and adjustable shelves in 25 mm grids



### ADDITIONAL STORAGE AND WORKING SURFACES

Thanks to the easy-to-clean, slip-resistant covers with raised edges.



### EASY TO MOVE WITH A FORKLIFT TRUCK

Thanks to the specific base, even when the cabinet is full.



### SECURE LOCK

Optionally with hinged or space-saving sliding doors.



Art. no. **816.278**  
Cabinet housing: pale grey, RAL 7035  
Fronts: ruby red, RAL 3003



Art. no. **815.312**  
Grey-white, RAL 9002  
(excl. partition material)

Art. no. **816.202**  
3-edge cover + 100R rubber for sliding doors cabinet 36+36x27U

Art. no. **816.156**  
3-edge cover + 100R rubber for cabinet housing 815.020

**36x27 U** 612 x 459 mm **W** 717 mm **D** 597 mm

H ↑	Drawer cabinets mm	Extendable shelves	kg	Lock	Art. no.
1020	1 × 75	2	75	KEY Lock	<b>815.300</b>
1020	1 × 75	2	200	KEY Lock	<b>815.301</b>
1020	2 × 75	1	75	KEY Lock	<b>815.302</b>
1020	2 × 75	1	200	KEY Lock	<b>815.303</b>
1020	3 × 75	1	75	KEY Lock	<b>815.304</b>
1020	3 × 75	1	200	KEY Lock	<b>815.305</b>
1020	3 × 75	2	75	KEY Lock	<b>815.306</b>
1020	3 × 75	2	200	KEY Lock	<b>815.307</b>
1020	4 × 75	-	75	KEY Lock	<b>815.308</b>
1020	4 × 75	-	200	KEY Lock	<b>815.309</b>
1020	5 × 75	-	75	KEY Lock	<b>815.310</b>
1020	5 × 75	-	200	KEY Lock	<b>815.311</b>
1000	-	-	-	KEY Lock	<b>815.003</b>

### Equipment

All drawer cabinets with a height of 1020 mm proposed on this page are equipped with: 3-sided edged cover, height 20 mm, including ribbed mat.



Art. no. **815.306**  
Cabinet housing: pale grey, RAL 7035  
Fronts: ruby red, RAL 3003  
(excl. partition material)

Art. no. **815.204**  
3-edge cover + 100R rubber

### 2-way forklift base for forklift trucks

Made of sheet steel, to be screwed to the base of the cabinet, can be painted according to colour chart. **Individual cover plate** mounted as front or rear lock.



Base for cabinet with hinged doors  
Dimensions (W × D × H mm)

**805.174**  
717 × 539 × 100

Base for cabinet with sliding doors  
Dimensions (W × D × H mm)

**816.204**  
1430 × 539 × 100





2 x 36x27 U 612 x 459 mm W → 1430 mm D ↗ 627 mm

H ↑	Drawer cabinets mm	Extendable shelves	🔒	🔑	Art. no.
1000	-	-	-	KEY Lock	816.008
1020	2 x 75	6	75	KEY Lock	816.270
1020	2 x 75	6	200	KEY Lock	816.271
1020	4 x 75	2	75	KEY Lock	816.272
1020	4 x 75	2	200	KEY Lock	816.273
1020	6 x 75	2	75	KEY Lock	816.274
1020	6 x 75	2	200	KEY Lock	816.275
1020	8 x 75	-	75	KEY Lock	816.276
1020	8 x 75	-	200	KEY Lock	816.277
1020	4 x 75	4	75	KEY Lock	816.278
1020	4 x 75	4	200	KEY Lock	816.279
1020	10 x 75	-	75	KEY Lock	816.280
1020	10 x 75	-	200	KEY Lock	816.281

**Equipment**

All drawers with a height of 1020 mm proposed on this double page are equipped with: 3-sided edged cover, height 20 mm, including ribbed mat.

2 x 36x36 U 612 x 612 mm W → 1430 mm D ↗ 780 mm

H ↑	Drawer cabinets mm	Extendable shelves	🔒	🔑	Art. no.
1000	-	-	-	KEY Lock	816.010
1020	4 x 75	2	75	KEY Lock	816.290
1020	4 x 75	2	200	KEY Lock	816.291
1020	4 adjustable shelves	2	75	KEY Lock	816.292
1020	4 adjustable shelves	2	200	KEY Lock	816.293
1020	4 x 75	4	75	KEY Lock	816.294
1020	4 x 75	4	200	KEY Lock	816.295

Forkable base for sliding door cabinet  
(2x 36x36 U) 816.205

3-edge cover for ribbed mat  
816.203

🔍 CNC tool holder and insert frame, see page 70-79

36x36 U 612 x 612 mm W → 717 mm D ↗ 750 mm

H ↑	Upper drawers mm	Drawer cabinets mm	Extendable shelves	🔒	🔑	Art. no.
1020	-	2 x 75	2	75	KEY Lock	815.320
1020	-	2 x 75	2	200	KEY Lock	815.321
1020	2 adjustable shelves	-	2	75	KEY Lock	815.322
1020	2 adjustable shelves	-	2	200	KEY Lock	815.323
1020	-	4 x 75	1	75	KEY Lock	815.324
1020	-	4 x 75	1	200	KEY Lock	815.325
3-edge cover + rubber 100R, no. 815.201						
1000	-	-	-	-	KEY Lock	815.007
1000	-	-	-	-	KEY Lock	815.020
UH 150+700mm						
1450	-	-	-	-	KEY Lock	815.012

Art. No. 815.021 3-sided edged cover + ribber mat for cabinet housing 815.007 e 815.012



🎨 For colour information, see fold-out page. When ordering, please specify the required colour (or colour combination).



# SOLID SAFETY AND SECURITY



## VERTICAL DRAWERS, FOR A HIGHER LEVEL OF OVERVIEW AND WORK SAFETY

A convenient space-saving solution with direct access to stored goods from both sides.



## ALWAYS SUITABLE FOR NEWLY STORED GOODS

Thanks to the flexibility of installing and repositioning drawers, pull-out shelves and adjustable shelves in 25 mm grids.



## HIGH STORAGE CAPACITY IN A SMALL SPACE REQUIREMENT

Thanks to shelf heights of up to 8.50 m.



## MAXIMUM EASE OF USE

With reversible and folding safety ladders for easy access to upper shelves and drawers.



## SECURE LOCK

Choose from roller shutters, hinged doors or space-saving sliding doors, with transparent insert as an option.



## HIGHLY STABLE

Thanks to its robust and stable design with a load-bearing capacity of up to 5.5 t per shelving unit.



## HEAVY-DUTY PULL-OUT SHELVES

With load capacities of up to 350 kg, for particularly large and heavy work pieces.



## VARIABLE EQUIPMENT OPTIONS

With various shelves.

Huni drawer storage walls are the optimal solution for the visible storage of large and heavy individual items or many small items, which are protected from dust and dirt. All elements, drawers, pull-out shelves and adjustable shelves can be freely combined, allowing for a wide range of equipment options, including for trucks and containers. The necessary conversions can be made by simply changing the single individual components. This means that you can change the structure at any time according to your logistical needs, always getting the solution for your needs. With all the benefits of our chests of drawers.



FULL COMPATIBILITY WITH HUNI PARTITION MATERIAL THANKS TO ONE STANDARD SIZE

See page 104



**Separate components**

- 1 Uprights
- 2 Rear panel or diagonals
- 3 Shelf side panel
- 4 Side panel cover
- 5 Top shelf
- 6 Adjustable shelf
- 7 Divider
- 8 Drawer
- 9 Fixed bottom shelf for lock
- 10 Pull-out shelf
- 11 Heavy-duty pull-out shelf
- 12 Vertical drawer frame\*
- 13 Vertical drawers\*
- 14 Shelf for vertical drawers\*
- 15 Lock for vertical drawers\*
- 16 Accessories for vertical drawers\*
- 17 Levelling plates
- 18 Fastening set
- 19 Ground frame
- Accessories for mobile equipment\*

\* Contact us for more information.

**VARIABLE EQUIPMENT OPTIONS**



**Drawers with telescopic extension**

- Load capacity 75 kg or 200 kg.
- Telescopic extension with rails without crossbars for perfect low-noise operation.



**Heavy-duty shelf**

- Load capacity up to 350 kg.
- Exceptionally low-noise operation.
- Available in wood or sheet steel and ribbed mats.



**Vertical drawers**

- Load capacity up to 200 kg (500 kg on request).
- For tidy, upright storage of pre-ordered tools.
- Optionally available with storage shelves, adjustable shelves, NC holders and perforated tops.



**Pull-out shelves with telescopic extension**

- Load capacity 75 kg or 200 kg.
- Telescopic extension with rails without crossbars for perfect low-noise operation.
- Sheet metal inserts, for flush mounting in the area.
- Pull-out shelves, optionally with slots for attaching heavy pieces.



**Adjustable and sealing shelves, dividers and shelf side panels**

- Adjustable shelves: load capacity up to 200 kg, can be attached without screws.
- Sealing shelves: load capacity up to 250 kg, screwable.
- Either plain or slotted for subdivision with dividers and shelf side panels.



**OPTION FOR INDIVIDUAL CONFIGURATIONS**

Huni's drawer storage walls are available in two depths and can be perfectly configured to your individual needs. Thanks to the standard dimensions, all separate components can be flexibly configured and combined and subsequently extended or modified

**Configuration examples**



**D 27 U**

**Installation depth 553 mm**

- Ideal for sites with limited space.
- Especially suitable for use in containers.
- Easier single-piece removal of heavy parts thanks to reduced depth.



**D 36 U**

**Installation depth 706 mm**

- Maximum flexibility thanks to a wide range of products and accessories.
- Vertical drawers and heavy-duty pull-out shelves can be used.
- Available in four widths.

**MAXIMUM STABILITY AND SAFETY**



**Sturdy side frames**

- For shelf heights up to 8.50 m, arranged on multiple tops.
- Option to cover with side paneling covers.
- On request, special installations, such as mobile equipment, are also available.

**FLEXIBLE APPLICATION OPTIONS AND MAXIMUM EASE OF USE**



**Safety ladders**

- Reversible and lockable for easy access to top shelves and drawers.



**Mobile equipment**

- In containers and trucks.



**Drug storage**

- Visible and within reach.



## DIMENSIONS AND LOAD CAPACITIES

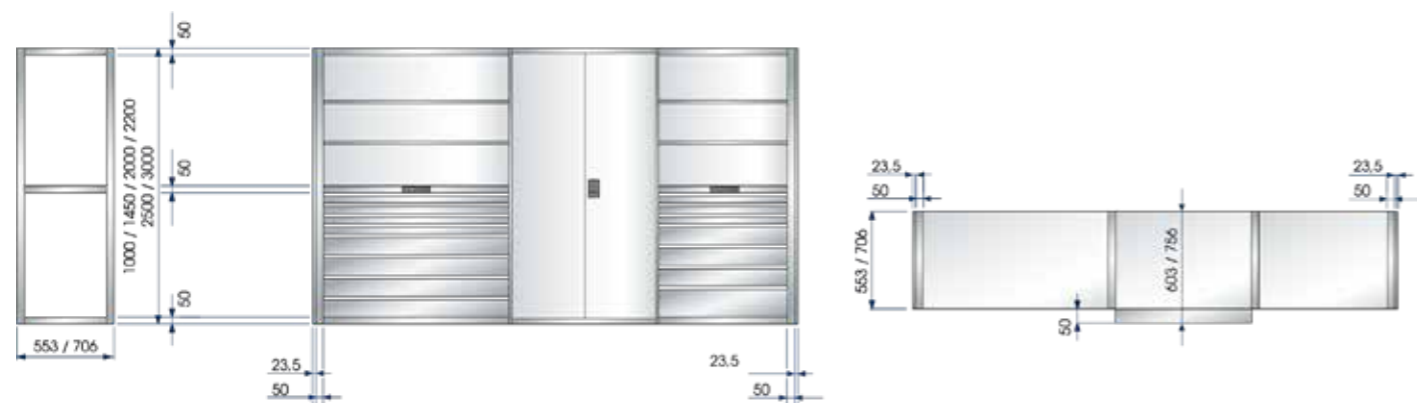

**G** = Shelf length (without side panels) = sum of usable width + sum of side panels. Shelf length (with side panels) = sum of usable width + sum of side panels + 47 mm.

### Shelving widths for depths 27 U and 36 U

Huni units	Depth 27 U & 36 U			
	36 U	54 U	64 U	78 U
Installation widths mm	664	970	1140	1378
Side frame	50	50	50	50
Side panel cover	23.5	23.5	23.5	23.5

### Arrangement of diagonals

The load capacities only apply if at least 2 of the 6 shelving sections are equipped with rear panels, or at least 3 in every 5 or one diagonal pair in every 3 shelving sections. From a height of 2200 mm and above, an additional universal shelf is required as a mezzanine floor for shelves. In the case of double-deck shelving systems, a diagonal pair or rear panels must be installed every 3 sections.



### Anchoring rule

All drawer storage walls must be anchored. An anchor is provided for each side frame. Exception: double-sided drawer storage walls, which are screwed together at the rear, must not be anchored.

**Note:** If only one pillar anchor is used, the anchor must be mounted at the rear.

### Shelf heights and load capacities

Heights in mm	Depth 27 U & 36 U					
	1000	1450	2000	2200	2500	3000
Clear heights	900	1350	1900	2050	2350	2850
<b>Load capacities per shelving unit</b>						
Min. number of universal shelves	2	2	2	3	3	3
Installation height above floor min/max of universal shelves mezzanine floors	-	-	-	900 - 1300	1050 - 1450	1300 - 1700
Load capacity per shelving unit	5500 kg	5000 kg	4500 kg	5500 kg	5250 kg	5000 kg

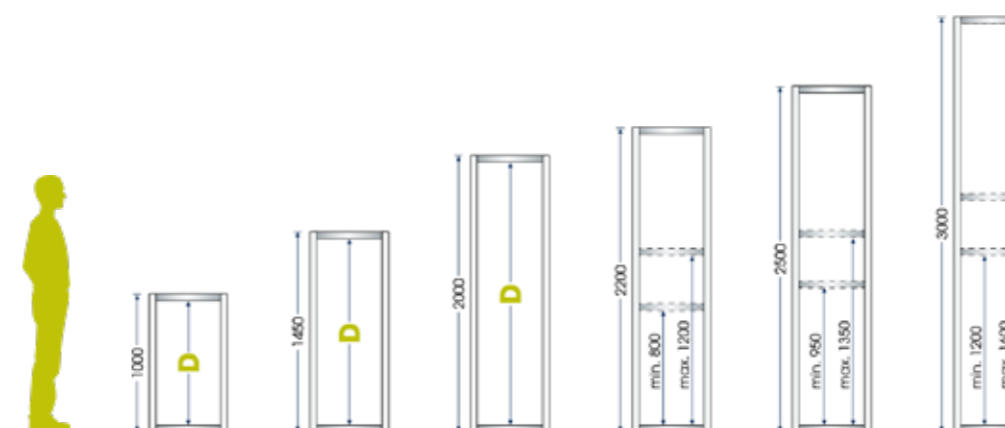

**D** = clear height = number of slots × 25 mm; slot in side frame every 25 mm, for installing shelves and drawers

## CUSTOMISE AND ORDER DRAWER STORAGE WALLS



Huni units

- Selection of shelf base area W × D (e.g.: 664 × 706 mm = 36 × 36 U).
- Huni U × U = unit of measure that helps in the selection of side frames, sealing elements, shelves, drawers and hinged doors.

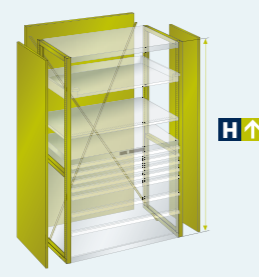

### 1 Side frames and sealing elements

- Choice of side uprights H.
- Choice of sealing elements: rear panel or diagonal.
- Floor anchoring, drawer storage walls must be anchored.
- Optional: levelling plates, frame top covering, tiles, side panels and pads.



### 2 Sealing shelves, for locks and

- Depending on the shelf height, a minimum number of sealing surfaces is required (see table).
- Lockable and fixed bottom shelves including lock are installed when the drawers are closed. In this case, the sealing shelves can be completely omitted or only countersunk as top shelves for the upper column lock.



### 3 Interior components

- Free choice of adjustable shelves, drawers, pull-out shelves and heavy-duty pull-out shelves.
- Optional: dividers for slotted adjustable shelves.
- Optional: see page 104 for partition material.



### 4 Additional components

- Swing doors, for part and full height.
- Sliding doors, roller shutters on request.

- !** For safety reasons, drawer storage walls must be fitted with at least the following components in accordance with regulations:
- Uprights.
  - Floor anchoring.
  - Rear panels OR diagonal pair.
  - Sealing shelves (plain or slotted).
  - Base frame.



**1 Side frames and sealing elements**

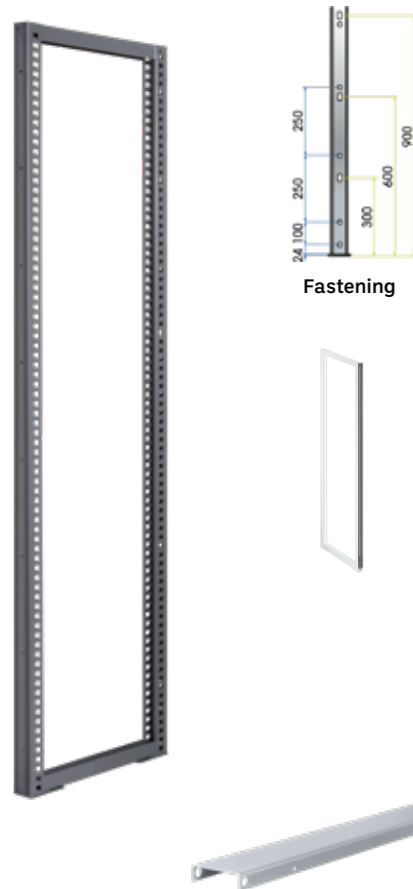

**Side frame**

Side frames with double-sided perforated partition in 25 mm grids, for attaching rails or brackets. The rear and front side frames are welded together by means of horizontal stabiliser struts, forming a stable frame. The side frames can be optionally fitted with screwed-on locking profiles. Drilled holes at the rear for screwing to the container wall with horizontal C-profiles. 1 floor anchor included. Description: side frames including horizontal stabiliser beams, in sheet steel profiles. Not suitable for locking profiles. Colours: according to colour chart.

**Locking profile**

Bolted locking profile for use of drawers and pull-out shelves in combination with single and double safety catch. Colours: according to colour chart.

Please contact our sales department for the correct uprights codes.

**Fill-in Strips**

Made of steel sheet, powder coating according to colour chart. They are used to cover the gaps between two shelves mounted at the same height (mezzanine tiles), between the shelves and the side panels (side tiles) or the upper part of the shoulders, between the vertically mounted shelves (upper tiles). Fastening material included.

D	Depth mm
27 U	553
36 U	706

D	Depth mm
27 U	52
36 U	52

Mezzanine tiles *	
D	Depth mm
27 U	552
36 U	706

Side tiles *	
27 U	553
36 U	706

Upper tiles	
27 U	553
36 U	706

\* Cannot be used with individual side support panels



**Rear panels**

Rear covers of the racks. They also provide lengthwise stability for the shelves. Can be used as a basic unit and add-on unit. Diagonal braces can also be used instead of the rear panels for stabilisation purposes. Description: sheet steel. Colours: according to colour chart. Impact profile: anthracite gray, RAL 7016.

or...



**Diagonal pair**

For lengthwise stability of the shelves instead of rear panels. Includes screws. Colours: according to colour chart.

Shelf height			
2000 mm	2200 mm	2500 mm	3000 mm
Art. no.	Art. no.	Art. no.	Art. no.
824.005	824.006	824.007	824.008
824.019	824.020	824.021	824.022

Art. no.	Art. no.	Art. no.	Art. no.
830.243	830.244	830.245	830.246
830.243	830.244	830.245	830.246

Art. no.	824.274
824.274	824.279

824.275	824.280
---------	---------

824.273	824.278
---------	---------

Art. no.	Art. no.	Art. no.	Art. no.
824.174	824.175	824.176	824.177
824.202	824.203	824.204	824.205
824.240	824.241	824.242	824.243
2 × 1000	1 × 1000, 1 × 1200	2 × 1000, 1 × 500	3 × 1000

On request, rear panels with square perforations, 10 × 10 mm and 38 mm grid, for holding keyhole hooks.

Art. no.	Art. no.	Art. no.	Art. no.
824.289	824.289	824.289	824.289
824.291	824.291	824.291	824.291
824.292	824.292	824.292	824.292



For safety reasons, drawer storage walls must be fitted with at least the following components in accordance with regulations.



**Leveling plates**

For height adjustment. They allow precise alignment even on uneven floors. Description: zincplated steel.

(plates already included in the standard uprights' article number)

	Art. no.
Thickness 1 mm	830.004
Thickness 2 mm	830.005
Thickness 4 mm	830.006



**Floor anchoring**

Drawer storage walls must be fixed to the floor (excluding drawer storage walls that are screwed together at the rear). An anchor is provided for each uprights. Requires 2 pieces per uprights.





**2 Universal shelves, lockable and fixed**



**End panel covers**

Shelving end caps. For attachment to end frame with fastening hooks. Fastening hook included. Description: sheet steel. Colours: according to colour chart.

D	Depth mm
27 U	553
36 U	706

Dimensions (W mm)

**Side walls**

For subsequent attachment to uprights. Particularly useful behind sliding doors, hinged doors and roller shutters as protection against theft. Can be used on the left and right. Description: sheet steel. Colours: according to colour chart.

D	Depth mm
27 U	553
36 U	706

**Shelf side panels**

They serve as a side cover when spaces cannot be closed with intermediate fill-in strips. They are countersunk into the side frames. Can also be used for folding fronts. Description: sheet steel. Colour: according to colour chart.

Delivery scope: in pairs (left and right version)  
\* Min. usable shelf height equal to height + 50 mm.

D	Depth mm
27 U	553
36 U	706

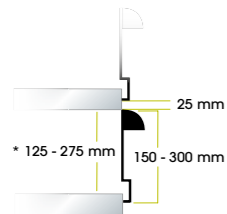

**Folding fronts**

Can be used with universal shelves. Folding downwards by 180 degrees. Supplied: double safety catch, label holder, handle cover and self-adhesive labels. Includes double ratchet. Colours: according to colour chart.

Dimensions of the installation mm		Depth 27 U	
W	D	36 x 27 U	54 x 27 U
664	553	664 x 553 mm	970 x 553 mm
Min. usable opening mm		Art. no.	Art. no.
150	125 *	830.221	830.226
200	175 *	830.222	830.227
250	225 *	830.223	830.228
300	275 *	830.224	830.229

**Plain sealing shelves**

They are screwed to the uprights as top and bottom locks or as mezzanine floors. Includes screws. Description: sheet steel. Colours: according to colour chart.

Sealing shelf		H 50 mm	
Art. no.	Art. no.	Art. no.	Art. no.
824.382	824.385	824.383	824.391
Load capacity (kg)		200	

**Plain adjustable shelves**

For attachment to side frames using fastening hooks, with welded strengthener. Includes 4 fastening hooks. Description: sheet steel. Colours: according to colour chart.

Adjustable shelf		H 25 mm	
Art. no.	Art. no.	Art. no.	Art. no.
824.516	824.593	824.590	824.595
Load capacity (kg)		150	

Shelf height			
2000 mm	2200 mm	2500 mm	3000 mm
Art. no.	Art. no.	Art. no.	Art. no.
824.058	824.059	824.060	824.061
824.070	824.071	824.072	824.073
23.5			
Optional rear panels with square perforations, 9 x 9 mm and 37 mm grid, for mounting keyhole hooks.			

Art. no.	Art. no.	Art. no.	Art. no.
824.123	824.124	824.125	824.126
824.135	824.136	824.137	824.138
Partition walls with square perforations, 9 x 9 mm and 37 mm pitch, for mounting keyhole hooks.			

Height between shelves mm	Min. distance shelves mm	Art. no.
150	200	824.297
200	250	824.298
250	300	824.299
150	200	824.300
200	250	824.301
250	300	824.302

Depth 36 U			
36 x 36 U	54 x 36 U	64 x 36 U	78 x 36 U
664 x 706 mm	970 x 706 mm	1140 x 706 mm	1378 x 706 mm
Art. no.	Art. no.	Art. no.	Art. no.
830.221	830.226	830.380	830.231
830.222	830.227	830.381	830.232
830.223	830.228	830.382	830.233
830.224	830.229	830.383	830.234
824.383	824.386	824.388	824.391
200			
824.590	824.595	-	-
150			

! For safety reasons, drawer storage walls must be fitted with at least the following components in accordance with regulations.



**Sealing and adjustable shelves**

The sealing shelves (load capacity 250 kg) are screwed to side frames. The adjustable shelves (load capacity 200 kg) are attached to the side frames using supports and can be adjusted in height. Usable dimensions: W 970 x D 701 mm.



**Pull-out shelves**

Used to store separate components and heavy materials, which can be stored flush with the handle using sheet metal intermediate fill-in strips. With telescopic extension. Load capacity 75 or 200 kg. Height-adjustable with 25 mm grid.

**3 Interior components**



**Drawers**

Made of sheet steel, powder coating according to colour chart. Drawers with different front heights can be installed in any drawer unit. All drawers with telescopic rails are fully extendable. The perimeter slotted walls with a 17 mm grid and the perforated base, together with the wide range of partition material, allow for the perfect adaptation to the stored pieces. The drawers have an aluminium handle complete with side, cardboard and cellulose caps.

**Ordering notes**

The clear height of the shelves is essential when selecting drawers. The sum of the front heights (C) must correspond to the clear height (B) (see diagram). Please refer to the installation instructions and loading guidelines for the load and drawer load capacity and drawer storage walls. The load capacity is calculated with an even load distribution. Please contact our sales department for the correct shelving configuration and code calculation.

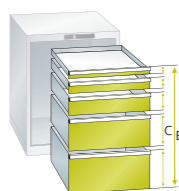

**Locking shelf and base frame**

The locking shelves and base frame are screwed to the side frames in the desired position and are prepared for the installation of **drawer locking systems**. Includes screws.  
Description: sheet steel. Colours: according to colour chart.

Depth 27 U
36 x 27 U

**75 kg**  
load capacity:

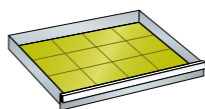

W → × D ↗	612 × 459 mm		Art. no.
H ↑	Clear height	H. body drawer	
50*	32	31	805.101
75	57	49	805.102
100	82	77	805.103
125	107	77	805.104
150	132	127	805.105
200	182	177	805.107
250	232	227	805.109
300	282	277	805.111

**200 kg**  
load capacity:

W → × D ↗	612 × 459 mm		Art. no.
H ↑	Clear height	H. body drawer	
75	57	49	805.127
100	82	77	805.128
125	107	77	805.129
150	132	127	805.130
200	182	177	805.132
250	232	227	805.134
300	282	277	805.136

W → × D ↗	664 × 553 mm		Art. no.
<b>Lockable shelf,</b> prepared for locking H 50 mm, load capacity 200 kg			824.415
<b>Base frame,</b> prepared for locking H 50 mm, load capacity 200 kg			824.310

Depth 27 U	Depth 36 U			
54 x 27 U	36 x 36 U	54 x 36 U	64 x 36 U	78 x 36 U

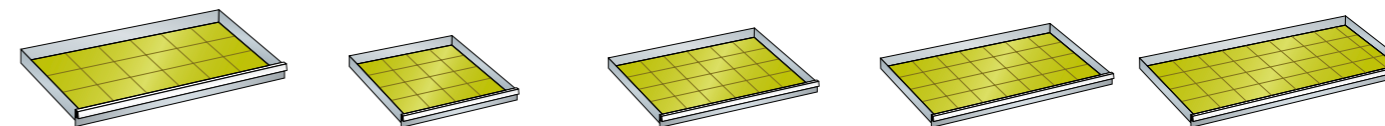

918 × 459 mm	612 × 612 mm	918 × 612 mm	1088 × 612 mm	1326 × 612 mm
Art. no.	Art. no.	Art. no.	Art. no.	Art. no.
809.101	806.101	810.101	-	-
809.102	806.102	810.102	812.102	-
809.103	806.103	810.103	812.103	-
809.104	806.104	810.104	-	-
809.105	806.105	810.105	-	-
809.107	806.107	810.107	-	-
809.109	806.109	810.109	-	-
809.111	806.111	810.111	-	-

\*Drawers with a front height of 50 mm can NOT be placed under a 200 kg load capacity drawer

918 × 459 mm	612 × 612 mm	918 × 612 mm	1088 × 612 mm	1326 × 612 mm
Art. no.	Art. no.	Art. no.	Art. no.	Art. no.
809.127	806.127	810.127	812.127	814.127
809.128	806.128	810.128	812.128	814.128
809.129	806.129	810.129	812.129	814.129
809.130	806.130	810.130	812.130	814.130
809.132	806.132	810.132	812.132	814.132
809.134	806.134	810.134	812.134	814.134
809.136	806.136	810.136	812.136	814.136

970 × 553 mm	664 × 706 mm	970 × 706 mm	1140 × 706 mm	1378 × 706 mm
Art. no.	Art. no.	Art. no.	Art. no.	Art. no.
824.417	824.416	824.418	824.420	824.419
824.313	824.311	824.315	824.317	824.320



For colour information, see fold-out page. When ordering, please specify the required colour (or colour combination).



**Base frame cover**

Made of sheet steel, powder coating according to colour chart. Choice between base frame cover for components raised from the base, and front cover for components placed at the bottom of the shelves.

Depth 27 U	
<b>36 x 27 U</b>	
664 x 553 mm	

Frame cover Art. no.	
824.328	

Front cover Art. no.	
824.355	

664 x 553 mm	
Art. no.	
-	

**Base frames, thickness 50mm**

Made of steel profiles, forming a rigid frame. Powder coating according to colour chart. They should be attached at the base of the supports. Prepared for supporting the rods for the locking unit. Fastening material included. Load capacity 200 kg with evenly distributed load.

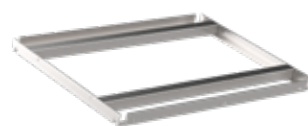

**Locks**

The central lock, to be installed in the lockable shelf, locks all drawers under the lock. Incl. cylinder, separately lockable, and locking rod.



H ↑	mm	Art. no.*
1000	900	824.656
1150	1050	824.659
1325	1225	824.663
1450	1350	824.666
1625	1525	824.670

Usable drawer dimensions		
W → × D ↗	664 x 553 mm	
Load capacity kg	min. clear height mm	Art. no.
75	75	805.151
200	75	805.152

Load capacity kg	min. clear height mm	Art. no.
350	215	-
Usable dimensions (W × D × H) mm		-

**Pull-out shelves**

Made of sheet steel, can be painted according to colour chart. Load capacity of pull-out shelves 75 kg or 200 kg. Thanks to the 25 mm grid in the vertical side frames of the cabinet housing, the shelves can be placed in the cabinet housing in the desired sequence.



**Heavy-duty pull-out shelf**

Heavy-duty pull-out shelves are mainly used in tool construction for the storage of appliances and tools. The structure is welded with side frames supported on multiple ballbearings. The guide rails are installed in the drawer storage walls without adaptation. Design: sheet steel profiles. Colour: grey, NCS S 4502-B.

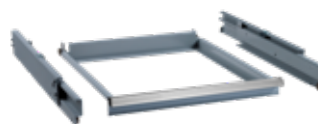

Depth 27 U	Depth 36 U			
54 x 27 U	36 x 36 U	54 x 36 U	64 x 36 U	78 x 36 U
1022 x 553 mm	716 x 706 mm	1022 x 706 mm	1140 x 706 mm	1430 x 706 mm

Art. no.	Art. no.	Art. no.	Art. no.	Art. no.
824.334	824.330	824.337	824.339	824.343

Cod. art.	Cod. art.	Cod. art.	Cod. art.	Cod. art.
824.358	824.355	824.358	824.361	824.362

1022 x 553 mm	716 x 706 mm	1022 x 706 mm	1140 x 706 mm	1430 x 706 mm
Art. no.	Art. no.	Art. no.	Art. no.	Art. no.
824.313	824.311	824.315	824.320	-

Art. no.*	Art. no.*	Art. no.*	Art. no.*	Art. no.*
824.656	824.712	824.712	824.712	824.712
824.659	824.718	824.718	824.718	824.718
824.663	824.725	824.725	824.725	824.725
824.666	824.730	824.730	824.730	824.730
824.670	824.737	824.737	824.737	824.737

\* Key lock codes - other lock types available on request.

1022 x 553 mm	716 x 706 mm	1022 x 706 mm	1140 x 706 mm	1430 x 706 mm
Art. no.	Art. no.	Art. no.	Art. no.	Art. no.
809.151	806.151	810.151	-	-
809.152	806.152	810.152	812.152	814.152

Art. no.	Art. no.	Art. no.	Art. no.	Art. no.
-	806.713	810.713	812.713	814.713
-	588 x 614 x 155	894 x 614 x 155	1064 x 614 x 155	1302 x 614 x 155





**Heavy-duty compartments and tops**

**Multiplex top:** For screwless insertion in heavy-duty pull-out shelves. Made of steam-impregnated beech veneer, glued in multiple layers, water-resistant, bevelled edges. Smoothed, oiled and waxed area. The top is splash-proof and resistant to dirt, oils and grease.

**Metal slat insert panels:** For screwless insertion in heavy-duty pull-out shelves. Design: sheet steel section, Sendzimir galvanised.

**Ribbed mats:** They serve as protection. To be placed on wooden supports or metal slat insert panels. Design: incl. adhesive tapes. Colour: black.

	Depth 27 U	
	36 x 27 U	664 x 553 mm
<b>W → × D ↗</b>		
<b>Multiplex top</b>	<b>Art. no.</b>	
	-	
Usable dimensions (W × D × H) mm	-	
<b>Metal slat insert panels</b>	<b>Art. no.</b>	
	-	
Number of metal slat insert panels	-	
Usable dimensions (W × D × H) mm	-	
<b>Ribbed mats</b>	<b>Art. no.</b>	
	-	
Usable dimensions (W × D × H) mm	-	

Depth 27 U	Depth 36 U			
	54 x 27 U	36 x 36 U	54 x 36 U	64 x 36 U
1022 x 553 mm	716 x 706 mm	1022 x 706 mm	1140 x 706 mm	1430 x 706 mm
<b>Art. no.</b>	<b>Art. no.</b>	<b>Art. no.</b>	<b>Art. no.</b>	<b>Art. no.</b>
-	806.714	810.714	812.714	814.714
-	588 x 614 x 50	894 x 614 x 50	1064 x 614 x 50	1302 x 614 x 50
<b>Art. no.</b>	<b>Art. no.</b>	<b>Art. no.</b>	<b>Art. no.</b>	<b>Art. no.</b>
-	806.715	810.715	812.715	814.715
-	588 x 614 x 54.5	894 x 614 x 54.5	1064 x 614 x 54.5	1302 x 614 x 54.5
<b>Art. no.</b>	<b>Art. no.</b>	<b>Art. no.</b>	<b>Art. no.</b>	<b>Art. no.</b>
-	806.716	810.716	812.716	814.716
-	588 x 614 x 3	894 x 614 x 3	1064 x 614 x 3	1302 x 614 x 3



**4** Additional components



**Hinged doors**

Made of sheet steel, powder-coated according to colour chart; a profile frame on which the doors are secured with concealed hinge bearing assemblies; can be screwed to the front of the adjustable shelves, locking shelf or base frame. Locks with vertical rods and safety cylinder. Drawers, pull-out shelves and adjustable shelves can be countersunk on the inside.



**Sliding doors**

Made of sheet steel, powder coating according to colour chart. They are applicable to the shelf by attaching them to the sealing shelves and the base frame. The widths cover two sections and allow the use of pull-out shelves, adjustable shelves and drawers. Lock with safety cylinder.

		Width 716 mm	Width 1022 mm	Width 1430 mm
		36 U	54 U	78 U
Upper section				
H ↑	Clear height mm	Art. no.	Art. no.	Art. no.
950	850	825.1097	825.1174	825.1251
1000	900	825.1099	825.1176	825.1253
1200	1100	825.1107	825.1184	825.1261
1450	1350	825.1117	825.1194	825.1271

Lower part				
H ↑	Clear height mm	Art. no.	Art. no.	Art. no.
950	850	825.866	825.943	825.1020
1000	900	825.868	825.945	825.1022
1200	1100	825.876	825.953	825.1030
1450	1350	825.886	825.963	825.1040
2000	1900	825.908	825.985	825.831



Shelves and/or base frames for door attachment will be supplied according to the shelving composition.

		Width 716 + 716 mm	Width 1022 + 1022 mm
		36 + 36 U	54 + 54 U
Upper section			
H ↑	Clear height mm	Art. no.	Art. no.
950	850	825.404	825.558
1000	900	825.406	825.560
1200	1100	825.416	825.570
1450	1350	825.424	825.578

Lower part			
H ↑	Clear height mm	Art. no.	Art. no.
950	850	825.019	825.096
1000	900	825.021	825.098
1200	1100	825.031	825.108
1450	1350	825.039	825.116
2000	1900	825.061	825.138



Shelves and/or base frames for door attachment will be supplied according to the shelving composition.



**Roller shutter doors**

The upper cover housing the roller shutter is made of sheet metal. The metal rails for sliding the shutter are attached to the vertical support pillars. The cover and rails are also attached to the top shelf. With snap lock and safety lock. Fastening material included.

		Width 716 mm	
		36 U	
		553 mm - 27 U	706 mm - 36 U
Clear height mm		Art. no.	Art. no.
2000	1900	824.910	824.910
2200	2100	824.911	824.911
2500	2400	824.912	824.912

		Width 1022 mm	
		54 U	
		553 mm - 27 U	706 mm - 36 U
		Art. no.	Art. no.
		824.921	824.921
		824.922	824.922
		824.923	824.923



**Side panels for roller shutter doors**

Made of sheet metal and steel structures, powder coating according to colour chart. The walls are fixed to vertical supporting pillars and cover the side of the cover. Fastening material included.

		Shoulder depth 552 mm	Shoulder depth 705 mm
		27 U	36 U
x		577 x 30 mm	730 x 30 mm
Shoulder height mm		Art. no.	Art. no.
2250	2000	824.103	824.109
2450	2200	824.104	824.110
2750	2500	824.105	824.111



Unless otherwise noted, all metal products are powder coated and available in the standard colour range.





# WORKSHOP PROFESSIONALS

Huni's NC storage and transport units are the perfect solution for workshop logistics. In fact, our NC modules not only allow you to store chip removal tools professionally in suitable storage units, but also to transport them safely. In addition, the tools are arranged in such a way to ensure they are visible without taking up too much space, yet always within reach and ready for immediate use. But that's not all: our NC modules can be set up according to individual requirements and can, of course, be combined with the entire Huni system to make optimum use of the valuable space in your production facility.



## MAXIMUM EASE OF USE AND ERGONOMICS

By means of tilting supports or pull-out shelves and drawers.



## SAFE TRANSPORT

Thanks to its robust and stable design.



## OPTIMUM USE OF SPACE

By positioning tools close to machines, reducing space, as well as considerable storage capacities.



## INDIVIDUAL AND SIMPLE EQUIPMENT

Due to the offset position of the tool holder sleeves.



## SAFE, CLEAN AND VISIBLE STORAGE

In high-quality housings made of break-resistant, impact-resistant and oil-resistant propylene (PP), which perfectly accommodates the chip removal tools.





**Transport trolleys**

Steel tube and sheet construction, powder coating according to colour chart. Vertical walls with hole grids at 25 mm intervals enable three tool frames to be attached at the same level. Equipped with four castors Ø 125 mm (two fixed and two swivel with brakes) and a handle.

Height mm	Width mm	Depth mm	Capacity kg*	Art. no.
905	740	510	40	<b>822.091</b>

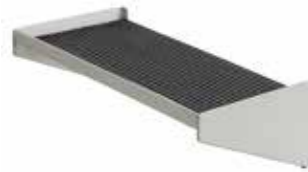

**Trolley bracket**

Made of sheet steel, with all-round edging and base with ribbed rubber mats. Can be screwed to the front wall. Fastening material included.

Width mm	Depth mm	Capacity kg*	Art. no.
500	200	100	<b>822.104</b>



**Adjustable shelves**

Made of sheet steel, with all-round edging and base with ribbed rubber mats. Can be screwed to vertical walls. Fastening material included.

H. edge mm	Width mm	Depth mm	Capacity kg*	Art. no.
20	600	290	80	<b>822.106</b>
20	600	490	120	<b>822.107</b>

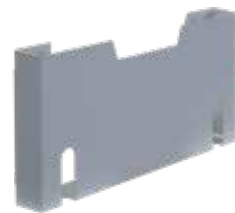

**Document pocket**

Made of sheet steel, colour grey RAL 7001. For storing drawings or technical documents with max. DIN A4. Can be screwed to a vertical wall. Fastening material included.

Height mm	Width mm	Depth mm	Art. no.
180	360	45	<b>822.108</b>



**Table stand**

Made of sheet steel, powder coating according to colour chart. For the support of max. three tool frames, finds its location on benches, cabinets, etc.

Height mm	Width mm	Depth mm	Art. no.
320	615	540	<b>822.126</b>

\* Load capacity with evenly distributed load.



**Tool cradles**

Made of sheet steel, colour grey RAL 7035. They are inserted into pairs of countersunk racks attached to the trolley walls or drawers. Length 592 mm, width 136 mm, load capacity 50 kg and one handle.

For tools	No. of tools per frame	Wheelbases mm	Height with handle	Height without handle	Art. no.
<b>SK 30</b>	14	74	155	100	<b>822.749</b>
<b>SK 40</b>	10	82	155	100	<b>822.750</b>
<b>SK 50</b>	4	120	189	134	<b>822.751</b>
<b>VDI 20</b>	16	66	155	100	<b>822.752</b>
<b>VDI 30</b>	14	74	155	100	<b>822.753</b>
<b>VDI 40</b>	10	82	155	100	<b>822.754</b>
<b>HSK 40</b>	14	74	155	100	<b>822.756</b>
<b>HSK 50</b>	10	82	155	100	<b>822.757</b>
<b>HSK 63</b>	8	85	155	100	<b>822.758</b>
<b>HSK 80</b>	5	110	155	100	<b>822.759</b>
<b>HSK 100</b>	4	120	155	100	<b>822.760</b>
<b>CAPTO C4</b>	14	74	155	100	<b>822.703</b>
<b>CAPTO C5</b>	10	82	155	100	<b>822.704</b>
<b>CAPTO C6</b>	10	82	155	100	<b>822.705</b>



**Trolley frame holder pairs**

Made of sheet steel, colour grey RAL 7035. For supporting tool holders in trolleys. They can be arranged horizontally or at an incline of 20°. Fastening material included. Art. no. **822.146**



**Pairs of frame supports for cabinets or drawer storage walls**

Made of sheet steel, colour grey RAL 7035. For supporting tool holders in cabinets or drawer storage walls. They can be arranged horizontally or at an incline of 20°. Fastening material included. Art. no. **822.154**



**Pairs of fixed drawer frames**

Made of sheet steel, colour grey RAL 7035. For supporting four tool holders. They are screwed to the bottom of the drawers. Fastening material included.

**3-seater 27 U** Art. no. **822.150**

**4-seater 36 U** Art. no. **822.151**





**Fixed frames 36 U**

For trolleys, cabinets, drawer storage walls and table stands. Made of sheet steel, colour grey RAL 7035. Frames complete with red PP bushings are screwed onto specific frame holder pairs. Fastening material included. Length 595 mm, width 150 mm.

For tools	Huni Unit	No.of tools per frame	Wheelbases mm	Art. no.
SK 40	36 U	12	82	822.763
SK 50	36 U	5	120	822.764
VDI 20	36 U	18	66	822.765
VDI 30	36 U	14	74	822.766
VDI 40	36 U	12	82	822.767
HSK 40	36 U	14	74	822.769
HSK 50	36 U	12	82	822.770
HSK 63	36 U	10	85	822.771
HSK 80	36 U	6	110	822.772
HSK 100	36 U	5	120	822.773
CAPTO C4	36 U	14	74	822.706
CAPTO C5	36 U	12	82	822.707
CAPTO C6	36 U	12	82	822.708



**Fixed frames 54 U**

For trolleys, cabinets, drawer storage walls and table stands. Made of sheet steel, colour grey RAL 7035. Frames complete with red PP bushings are screwed onto specific frame holder pairs. Fastening material included. Length 901 mm, width 150 mm.

For tools	Huni Unit	No.of tools per frame	Wheelbases mm	Art. no.
SK 40	54 U	18	82	822.820
SK 50	54 U	8	120	822.821
VDI 20	54 U	27	66	822.822
VDI 30	54 U	21	74	822.823
VDI 40	54 U	18	82	822.824
HSK 40	54 U	21	74	822.826
HSK 50	54 U	18	82	822.827
HSK 63	54 U	15	85	822.828
HSK 80	54 U	9	110	822.829
HSK 100	54 U	7	120	822.830
CAPTO C4	54 U	21	74	822.712
CAPTO C5	54 U	18	82	822.713
CAPTO C6	54 U	18	82	822.714

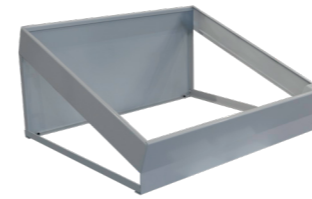

**Table stand for fixed frames**

Made of sheet steel, painted according to colour chart. To support max. three fixed tool holder frames, finds its location on benches, cabinets, etc.

Height mm	Width mm	Depth mm	Art. no.
320	645	540	822.125



**Pairs of fixed frame supports for cabinets and drawer shelves**

Made of sheet steel, colour grey RAL 7035. For support in cabinets and shelves, at an inclined position of 20°. Fastening material included.

Length in Huni units	Frame no.	Art. no.
27 U	3	822.155
36 U	4	822.156

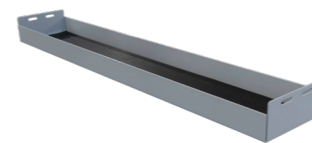

**Frames with tubs**

Made of sheet steel, colour grey RAL 7035. The base of the tub is covered with a ribbed rubber floor mat. They are screwed to the frame support pairs. Used for storing long cutter holders. Load capacity 30 kg with evenly distributed load.

Huni Unit	Width mm	Length mm	Art. no.
36 U *	150	600	822.417
54 U **	150	906	822.460

\* Trolleys and cabinets.  
\*\* Cabinets only



**Holder CN 36 x36 U**

Made of sheet steel, colour grey RAL 7016. The holders complete with red sleeves are placed directly on the bottom of the 36x36U drawers. Length 598 mm, width 598 mm.

For tools	Height without tool holder	No.of tools per holder	Wheelbases mm	Art. no.
SK30	100	52	82	822.719
SK 40	100	52	82	822.720
SK 50	145	25	120	822.721
VDI 20	60	81	66	822.722
VDI 30	60	64	74	822.723
VDI 40	60	52	82	822.724
HSK 40	60	64	74	822.725
HSK 50	60	52	82	822.726
HSK 63	60	39	85	822.727
HSK 80	60	25	110	822.728
HSK 100	60	20	120	822.729
CAPTO C4	60	64	74	822.730
CAPTO C5	60	52	82	822.731
CAPTO C6	60	52	82	822.732





**Roller shutter cabinets for storage CN tools**

Made of sheet metal and steel construction, can be anchored to the floor. PVC roller shutter with cylinder safety lock. The side frames are perforated in a grid 25 mm for attaching fixed or interchangeable drawer rails (see accessories page 52-53-54-55)

Total height mm	Usable height mm	Width mm	Depth mm	Art. no.
1700	1350	717	774	<b>817.001</b>
1875	1525	717	774	<b>817.003</b>



**Cabinets with integrated roller shutter**

Made of sheet metal and steel construction, can be anchored to the floor. PVC roller shutter with cylinder safety lock. The side frames are perforated at 25 mm intervals for attaching drawers and shelves. It is possible to purchase the corresponding forkable base (H=100 mm) with article no. **817.205**.

Height Total mm	Usable height mm	Width mm	Depth mm	Art. no.
1450	1200	1023	692	<b>817.005</b>
2000	1750	1023	692	<b>817.006</b>



**Trolley frame holder pairs**

Made of sheet steel, colour grey RAL 7035. For supporting tool holders in trolleys. They can be arranged horizontally or at an incline of 20°. Fastening material included. Art. no. **822.145**



A maximum of 5 panels per side can be mounted in the **H = 2000 mm** cabinet, and a maximum of 3 panels per side in the **H = 1450 mm** cabinet.



**Side perforated panels**

The perforated panels are attached between the front and rear support pillars and are required for mounting the swap cradles. Thanks to these pegboards, the frames can be mounted in any position.

Height mm	Width mm	Art. no.
320	530	<b>817.204*</b>

\* Code refers to one piece



**Frame support pairs**

Made of sheet steel, colour grey RAL 7035. For supporting fixed frames in an inclined position of 20°. Fastening material included.

Length in Huni units	Frame no.	Art. no.
27	3	<b>822.155</b>



**Reduced adjustable shelf**

Height mm	Width mm	Depth mm	Capacity kg*	Art. no.
25	967	475	150	<b>817.201</b>
50	969	475	200	<b>824.458</b>

\* Load capacity with evenly distributed load.

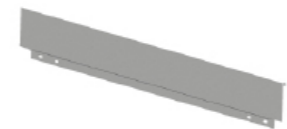

**Bulkhead containment**

Partition wall to be mounted, interlocking, on the back of the adjustable shelves to prevent stored material from interfering with the locking rod or the slider.

Height mm	Length mm	Art. no.
100	965	<b>817.203</b>



**Adjustable shelf**

Made of sheet steel, powder coating according to colour chart. The shelf, which is secured with hooks, does not need to be screwed to the side frames and can therefore be quickly removed and repositioned at the desired height.

Height Total mm	Usable width mm	Usable depth mm	Capacity kg	Art. no.
25	967	548	150	<b>817.200</b>

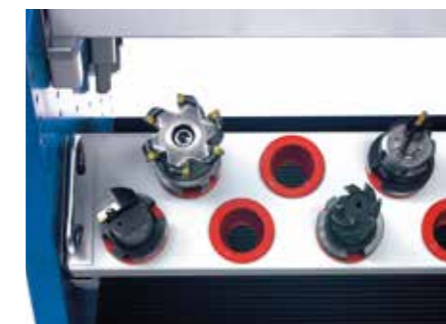



**Tool cradles**

The frames are attached to the perforated panels with frame supports.

For tools	Huni Unit	No.of tools per frame	Wheelbases mm	Art. no.
SK 40	54 U	18	82	822.835
SK 50	54 U	8	120	822.836
VDI 20	54 U	27	66	822.837
VDI 30	54 U	21	74	822.838
VDI 40	54 U	18	82	822.839
HSK 40	54 U	21	74	822.841
HSK 50	54 U	18	82	822.842
HSK 63	54 U	15	85	822.843
HSK 80	54 U	9	110	822.844
HSK 100	54 U	7	120	822.845
CAPTO C4	54 U	21	74	822.715
CAPTO C5	54 U	18	82	822.716
CAPTO C6	54 U	18	82	822.717



**Tool cradles**

The frames are attached to the perforated panels with frame supports.

For tools	Huni Unit	No.of tools per frame	Wheelbases mm	Height with handle mm	Height without handle mm	Art. no.
SK 30	36 U	14	74	155	100	822.749
SK 40	36 U	10	82	155	100	822.750
SK 50	36 U	4	120	189	134	822.751
VDI 20	36 U	16	66	155	100	822.752
VDI 30	36 U	14	74	155	100	822.753
VDI 40	36 U	10	82	155	100	822.754
HSK 40	36 U	14	74	155	100	822.756
HSK 50	36 U	10	82	155	100	822.757
HSK 63	36 U	8	85	155	100	822.758
HSK 80	36 U	5	110	155	100	822.759
HSK 100	36 U	4	120	155	100	822.760
CAPTO C4	36 U	14	74	155	100	822.703
CAPTO C5	36 U	10	82	155	100	822.704
CAPTO C6	36 U	10	82	155	100	822.705

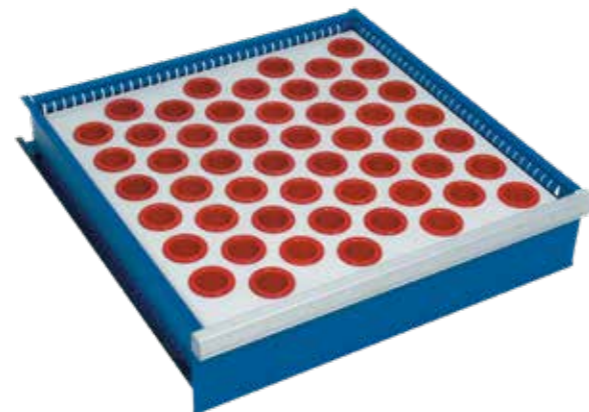

**Drawers**

Made of sheet steel, powder coating according to colour chart. Usable dimensions 918 x 429 mm (54 x27 U). Drawers with different front heights can be installed in any drawer unit. The sum of the front heights must correspond to the usable height of the drawer unit. All drawers with telescopic rails are fully extendable. The perimeter slotted walls with a 17 mm grid and the perforated base, together with the wide range of partition material, allow for the perfect adaptation to the stored pieces. The drawers have an aluminium handle complete with side caps, cardboard and cellux.

Front height	Usable height 75 kg	Usable height 200 kg	Lateral height	Art. no. 75 kg*	Art. no. 200 kg*
50	32	-	31	809.101	-
75	57	54	49	809.102	809.127
100	82	79	77	809.103	809.128
125	107	104	77	809.104	809.129
150	132	129	127	809.105	809.130
175	157	154	127	809.106	809.131
200	182	179	177	809.107	809.132
250	232	229	227	809.109	809.134
300	282	279	277	809.111	809.136

\* Load capacity with evenly distributed load.



**Locking mechanism and rod support crossbar**

If drawers or pull-out shelves are fitted, the vertical locking rod must be fitted to prevent the cabinet from tipping over, as only one drawer or shelf can be pulled out at a time. The pole is secured with a support crossbar.

Art. no. 817.202

Useful height	Art. no.
300	817.206
450	817.207
550	817.208
600	817.209
700	817.210
750	817.211
900	817.212
1050	817.213
1200	817.219
1225	817.214
1250	817.218
1350	817.215
1525	817.216
1750	817.225
1850	817.217

**Cardboard + Cellux (10 pcs)**

Art. no. 828.267

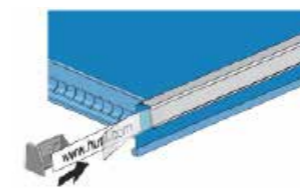

**Safety Catch**  
Art. no. 828.270

**Rod support crossbar**  
Art. no. 817.202





# OPTIMAL ORGANISATION



## MAXIMUM STABILITY

Solid workbench, withstands up to 3 t, extremely robust and durable countertops.



## GREAT DESIGN DIVERSITY

Thanks to a variety of components, substructures, materials and surfaces.



## ALWAYS ADAPTABLE TO NEW WORK ENVIRONMENTS

Thanks to the flexibility of installing and modifying all components of the modular system.



## SIMPLE AND QUICK TO ASSEMBLE

With countertops prepared for pre-assembly (incl. threaded intermediate fill-in strips) and for fixing all substructures and drawer cabinets.



## ERGONOMICS & HEALTH

With height-adjustable workstation supports for optimum ergonomics while working, as well as maximum legroom when sitting, supported by our modular body system.



## COMPLETE MOBILITY

With equipment with rubber castors, for moving to different workstations.

Thanks to the various combination possibilities, Huni workbenches allow you to organise every workstation individually and save space. Workbench tops combined with drawer cabinets and covered walls can be arranged to create optimal working conditions. All this, of course, taking into account the latest ergonomics studies along with reliable Huni quality, even for the harshest working environments found in workshops and heavy industry.



## THE RIGHT SOLUTION FOR EVERY NEED



Workstations  
see page 82



Hexagonal workbenches  
(upon request)



Workstations  
(upon request)



Test and inspection  
workstations  
see page 94

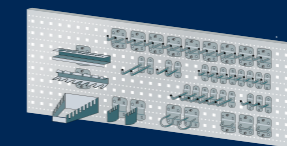

Keyhole hooks  
see page 97



# WORKSTATIONS

With a huge choice of combinations, Huni's workbenches allow you to organise every workstation individually and save space. Workbench tops that can be combined with workbench leg assemblies, drawer units, vice cabinets and perforated panels can be arranged to create optimal working conditions. All this, of course, taking into account the latest ergonomics studies along with the robust Huni quality, even for the toughest working environments in workshops and heavy industry.



## MAXIMUM STABILITY

Solid workbench, withstands up to 3 t, extremely robust and durable countertops.



## COMPLETE MOBILITY

In the version with rubber castors for moving to different workstations.



## MAXIMUM EASE OF USE AND ERGONOMICS

With height-adjustable workbench leg assemblies for maximum ergonomics during work and maximum legroom when sitting, thanks to our modular superstructure system.



## SIMPLE AND QUICK TO ASSEMBLE

thanks to pre-drilled workbench tops (pre-assembled intermediate fill-in strips) and fastening material (included) for all substructures and drawer cabinets



## DIVERSE SUBSTRUCTURES



Contact us for ordering information.

### Workbench leg assemblies

- Sturdy sheet steel construction.
- Welded from extruded profiles.
- With holes for fixing worktops and countertops.

### Castors for mobility

- For removable workbenches.
- Swivelling and fixed castors including brakes.
- Rubber-coated castors, for soft and hard floors respectively.

## ORDER PRECONFIGURED TEMPLATES

### ...OR CONFIGURE AND ORDER INDIVIDUAL WORKBENCHES

### UNIVERSAL SUPERSTRUCTURES

Combine substructures and countertops freely and flexibly with the universal superstructures of the Huni system: various modules and accessories are available, from the rear panel to the monitor base.

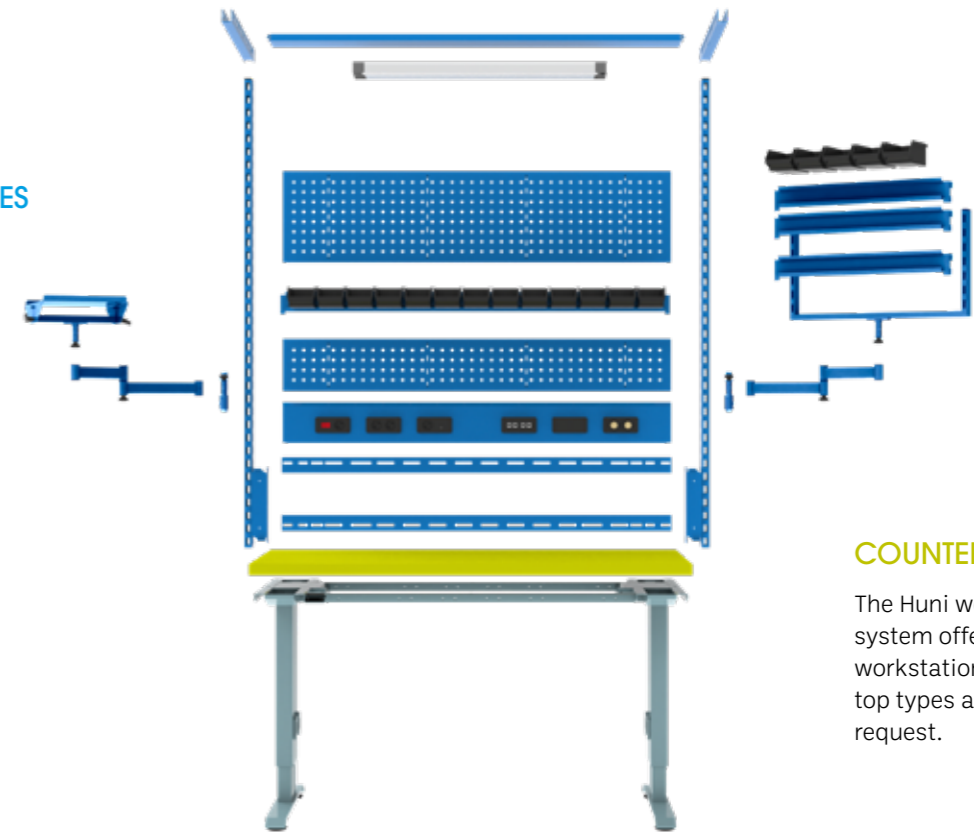

### COUNTERTOPS

The Huni workstation system offers 5 standard workstation widths. Other top types and dimensions on request.

### SUBSTRUCTURE

Depending on the application and field of application, you can choose between different substructures.



Art. no. **827.879**  
Pale blue, RAL 5012



### Multi-layer top

With multilayer tops, including pre-assembly and fastening material. Drawer unit can be mounted on the right or left.

**Thickness 40 mm.** Made of steam-impregnated beech veneer, glued multilayer, water-resistant, bevelled corners, smoothed, oiled area. The top is splash-proof, dirt-repellent and completely resistant to oil and grease.

**D** 800 mm **459 x 612 mm**

Workbenches with drawer cabinets dimensions \*

**27 x 36 U**



W →	D ↗	H ↑	Top	Number of drawers mm	Icon	Lock	Art. no.
1500	800	840	Multi-layer	4: 1 × 50/2 × 100/1 × 200	600	KEY Lock	<b>827.873</b>
1500	800	890	Multi-layer	4: 1 × 50/2 × 100/1 × 200	600	KEY Lock	<b>827.874</b>
2000	800	840	Multi-layer	4: 1 × 50/2 × 100/1 × 200	360	KEY Lock	<b>827.875</b>
2000	800	890	Multi-layer	4: 1 × 50/2 × 100/1 × 200	360	KEY Lock	<b>827.876</b>
1500	800	840	Multi-layer	4: 2 × 100/1 × 200/1 × 300	1500	KEY Lock	<b>827.877</b>
2000	800	840	Multi-layer	4: 2 × 100/1 × 200/1 × 300	800	KEY Lock	<b>827.878</b>
1500	800	840	Multi-layer	5: 1 × 50/2 × 100/1 × 150/1 × 300	1500	KEY Lock	<b>827.879</b>
2000	800	840	Multi-layer	5: 1 × 50/2 × 100/1 × 150/1 × 300	800	KEY Lock	<b>827.880</b>
1500	800	890	Multi-layer	5: 2 × 100/1 × 150/2 × 200	1500	KEY Lock	<b>827.881</b>
2000	800	890	Multi-layer	5: 2 × 100/1 × 150/2 × 200	800	KEY Lock	<b>827.882</b>
1500	800	890	Multi-layer	5: 1 × 50/2 × 100/2 × 150/1 × 200	1500	KEY Lock	<b>827.883</b>
2000	800	890	Multi-layer	5: 1 × 50/2 × 100/2 × 150/1 × 200	800	KEY Lock	<b>827.884</b>

**D** 800 mm **459 x 612 mm**

Workbenches with drawer cabinets dimensions \*

**27 x 36 U**



W →	D ↗	H ↑	Top	Number of drawers mm	Icon	Lock	Art. no.
1500	800	840	Multi-layer	-	600	-	<b>827.830</b>
1500	800	890	Multi-layer	-	600	-	<b>827.831</b>
1500	800	740 - 1090	Multi-layer	-	600	-	<b>827.860</b>
2000	800	840	Multi-layer	-	360	-	<b>827.861</b>
2000	800	890	Multi-layer	-	360	-	<b>827.832</b>
2000	800	740 - 1090	Multi-layer	-	360	-	<b>827.862</b>
1500	800	840	Multi-layer	1: 1 × 150	600	KEY Lock	<b>827.863</b>
1500	800	890	Multi-layer	1: 1 × 150	600	KEY Lock	<b>827.864</b>
2000	800	840	Multi-layer	1: 1 × 150	360	KEY Lock	<b>827.865</b>
2000	800	890	Multi-layer	1: 1 × 150	360	KEY Lock	<b>827.866</b>
1500	800	840	Multi-layer	3: 1 × 50/1 × 100/1 × 150	600	KEY Lock	<b>827.867</b>
1500	800	890	Multi-layer	3: 1 × 50/1 × 100/1 × 150	600	KEY Lock	<b>827.868</b>
1500	800	740 - 1090	Multi-layer	3: 1 × 50/1 × 100/1 × 150	600	KEY Lock	<b>827.869</b>
2000	800	840	Multi-layer	3: 1 × 50/1 × 100/1 × 150	360	KEY Lock	<b>827.870</b>
2000	800	890	Multi-layer	3: 1 × 50/1 × 100/1 × 150	360	KEY Lock	<b>827.871</b>
2000	800	740 - 1090	Multi-layer	3: 1 × 50/1 × 100/1 × 150	360	KEY Lock	<b>827.872</b>



### Workstations

With multilayer tops, including pre-assembly and fastening material. Drawer unit can be mounted on the right or left.

Multilayer top thickness	<b>40 mm</b>
Workbench leg assembly height	800/850 mm
height adjustable**	750 - 1050 mm
Drawer unit width	564 mm
Drawer unit depth	725 mm
Drawer load capacity	75 kg

Loads see page 93

\* These workbench order examples are equipped with 27 × 36 E drawer cabinets. Each workbench is also available with the following drawer cabinet dimensions:  
 27 × 27 U = 459 × 459 mm (W × D)  
 36 × 27 U = 612 × 459 mm (W × D)  
 18 × 36 U = 306 × 612 mm (W × D)  
 36 × 36 U = 612 × 612 mm (W × D)





**D** 800 mm **459 × 459 mm** Workbenches with drawer cabinets dimensions \* **27 × 27 U**

	W →	D ↗	H ↑	Top	Number of drawers mm	kg	Lock	Art. no.
	1500	800	840	Multi-layer	-	600	-	827.830
	1500	800	890	Multi-layer	-	600	-	827.831
	2000	800	840	Multi-layer	-	360	-	827.861
	2000	800	890	Multi-layer	-	360	-	827.832
	1500	800	840	Multi-layer	3: 1 × 50/1 × 100/1 × 150	600	KEY Lock	827.833
	1500	800	890	Multi-layer	3: 1 × 50/1 × 100/1 × 150	600	KEY Lock	827.834
	2000	800	840	Multi-layer	3: 1 × 50/1 × 100/1 × 150	360	KEY Lock	827.846
	2000	800	890	Multi-layer	3: 1 × 50/1 × 100/1 × 150	360	KEY Lock	827.835
	1500	800	840	Multi-layer	4: 2 × 100/1 × 200/1 × 300	1500	KEY Lock	827.836
	2000	800	840	Multi-layer	4: 2 × 100/1 × 200/1 × 300	800	KEY Lock	827.837
	1500	800	840	Multi-layer	5: 1 × 50/2 × 100/1 × 150/1 × 300	1500	KEY Lock	827.838
	2000	800	840	Multi-layer	5: 1 × 50/2 × 100/1 × 150/1 × 300	800	KEY Lock	827.839
	1500	800	890	Multi-layer	5: 2 × 100/1 × 150/2 × 250	1500	KEY Lock	827.840
	2000	800	890	Multi-layer	5: 2 × 100/1 × 150/2 × 250	800	KEY Lock	827.841
	1500	800	890	Multi-layer	6: 1 × 50/2 × 100/2 × 150/1 × 200	1500	KEY Lock	827.842
	2000	800	890	Multi-layer	6: 1 × 50/2 × 100/2 × 150/1 × 200	800	KEY Lock	827.843



Art. no. **827.833**  
Structure: pale grey, RAL 7035  
Fronts: pale blue, RAL 5012

### Workstations

With multilayer tops, including pre-assembly and fastening material. Drawer unit can be mounted on the right or left.

Multilayer top thickness  
**40 mm**  
Workbench leg assembly height 800/850 mm  
Drawer unit width 564 mm  
Drawer unit depth 572 mm  
Drawer load capacity 75 kg

Loads see page 93

\* These workbench order examples are equipped with 27 × 27 U drawer cabinets. Each workbench is also available with drawer cabinet dimensions 36 × 27 U = 612 × 459 mm (W × D)





**Static, fixed-height and adjustable workbench leg assemblies**

The Huni workbench leg assembly is a sturdy sheet steel construction made of extruded and welded profiles with holes for fixing the tops. The base is secured by a perforated levelling plate. Load capacity 400 kg. Calculate the max. working width. on page 93. Description: sheet steel. Colour: according to colour chart.

Height mm	For top depth mm	Top thickness mm	Width mm	Depth mm	Art. no.
800	750	40	80	722	827.151
830	750	40	80	722	82.154
850	750	40	80	722	827.155
750 - 1050 *	750	40	80	722	827.180



**Workbench leg assemblies, movable and height-adjustable**

Rubber tread castors are available. Width: 80 mm. Depth: 722 mm. Height: 750 - 1050 mm. Calculate the max. working width on page 93. Description: sheet steel. Colour: according to colour chart.

Description	 Castor	Castor ø mm	Art. no.
With handle, without castors	400	-	827.171
With 2 rubber fixed castors	200	100	827.169
With 2 rubber swivel castors, parking breaks	200	100	827.170

 Workbenches on castors must be equipped with a handle in accordance with the German Product Safety Act. For stability reasons, a strut must also be installed on workbenches with castors.

**Fixed leg supports**

For stabilising workbench leg assemblies (e.g. for mobile workbench leg assemblies). Incl. fastening material. Description: sheet steel. Colour: according to colour chart.

Bench length mm	Leg support length mm	No. of brackets per bench	Art. no.
1250	744	2	827.342
1500	994	2	827.337
1750	1244	2	827.343
2000	1494	2	827.334
2500	1994	2	827.332
2500	959	3	827.333
3000	1209	3	827.331

**Angle for fastening the storage shelf to the drawer unit**

Fastening material included. Description: sheet steel. Colour: according to colour chart

By storage shelf depth	Workbench depth mm	Art. no.
620	540	827.481

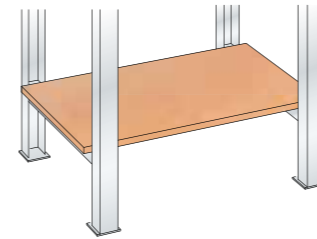
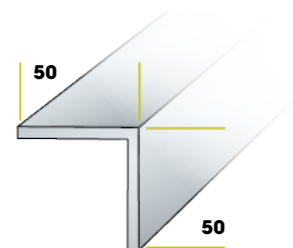

**Substructures between workbench leg assemblies**

Thickness 25 mm, max. load capacity 20 kg. Description: multi-layer top, pre-drilled, including fastening material.

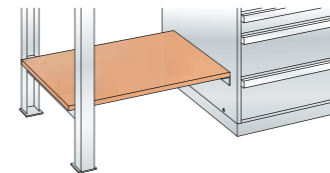

**Substructures between workbench leg assembly and cabinet**

Thickness 25 mm, max. load capacity 20 kg. Description: Multi-layer top, pre-drilled, including fastening material, without storage shelf bracket.

Depth of storage shelf mm	620	
For workbench leg assemblies depth mm	725	
Width of top mm	Width mm	Art. no.
1500	1200	827.509
1750	1450	827.510
2000	1700	827.511
2500	2200	827.512
3000	2700	827.513

Depth of storage shelf mm	620	
For workbench leg assemblies depth mm	725	
Drawer cabinet depth mm/Huni unit	725/36 U	
Width of top mm	Width mm	Art. no.
1500	765	827.514
1750	1015	827.515
2000	1265	827.516
2500	1765	827.517
3000	2265	827.518



**Drawer cabinets**

Each workbench is available with drawer cabinets in the following dimensions:

**27x27 U** = 459 x 459 mm (W x D)

**27x36 U** = 459 x 612 mm (W x D)

**36x27 U** = 612 x 459 mm (W x D)

**36x36 U** = 612 x 612 mm (W x D)

**Bench drawer Type J 12**

Sheet steel construction, powder coating according to colour chart. Useful for storing all the tools that are normally used on the countertop. Equipped with a fully extendable drawer with telescopic rail and cylinder lock, it is mounted under the wooden top with screws. Drawers with telescopic rails, fully extendable.



Height mm	Drawer height mm	Usable height mm	Width mm	Depth mm	Art. no.
204	150	150	578	725	827.581





From the multilayer top to the resin top, the Huni workstation system offers the right worktop for every application. Another advantage: when the side frames for superstructures are fixed behind the countertops, you can use the full countertop depth with the Huni system.

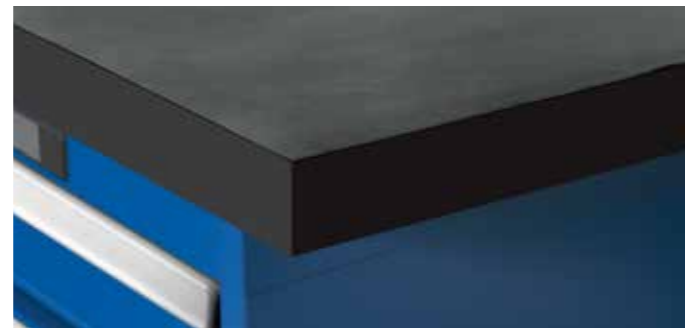

**Multi-layer top**

- Beech veneer, steam impregnated, water resistant and bevelled corners.
- Smoothed, oiled area.
- For universal use, waterproof, dirt-repellent and completely resistant to oils and greases.

**Nitrile plate**

- Technical surface made of natural rubber.
- 4 mm rubber coating, with 2 mm ABS edges, black.
- Medium-hard, non-slip, impact-resistant and resistant to oils and mostly to fuels.
- Can be used at temperatures between -10 °C and +70 °C.
- Slight opacity or scratches due to the manufacturing process and conforming to the normal surface characteristics of the product.



**Metal claddings (on request)**

- For high demands.
- Very easy to clean and versatile.
- Available in galvanised or chrome-plated steel.

**Resin top**

- Colour: pale grey.
- Easy-to-clean top surface texture with HPL coating, 0.8 mm.
- Resistant to common household chemicals, solvents, weak acids and alkalis.
- High impact and scratch resistance.
- Also available in ESD version.
- With 2 mm ABS edging, grey.

**Height-adjustable shelves**

Allows shelves with raised edges to be moved to four different heights. Positioning height above the tops: 230, 270, 310 and 350 mm. They are screwed to the workbench top (pre-assembly required). Fastening material included. Description: made of square steel tube, including fastening material per piece. Colour according to colour chart.

Designation	Depth mm	Art. no.
Height-adjustable shelves	280	827.371

Characteristics	Multi-layer	Nitrile **	Metal coatings	Resin
Shock and scratch resistance	●	■	●	
Scratch resistance		○	■	■
Absorption		■		
Cleanliness/hygiene			■	■
Heat resistance (welding)			■	○
Chemical resistance *		○	■	●
Acid resistance *		○	■	●
Alkali resistance *		○	■	●
Resistance to oil and grease *		●	■	●

\* Incl. visual changes  
 \*\* Resistance: good for oils, good/limited for fuels, not recommended for acids, alkalis and acetone. Changes and slight swelling of the surface may occur due to work with chemicals, oils, soaps, etc., which are attributable to the material quality and do not constitute a product defect. Exclusive threaded inserts (pre-assembled) and fastening material. Must be ordered separately according to substructure.

● Completely  
 ○ Partially  
 ■ In most cases

! The recommendations concerning resistance are only general guidance and do not take into account the incidence of secondary factors such as substance concentration, temperature, oxidation, etc. The information provided is therefore not binding. Depending on the substance, prior examination is strongly recommended.



**Shelves with raised edge**

Description: MDF top with raised beech edge on three sides (rear and side), height 8 mm. Depth 300 mm, thickness 25 mm. Max. capacity 20 kg per metre. Without base colour on all sides, without brackets (see below). Max. distance between shelf supports 1100 mm.

By width top mm	Brackets required	Art. no.
1500	2	827.372
1750	2	827.373
2000	2	827.374
2500	3	827.375
3000	4	827.376

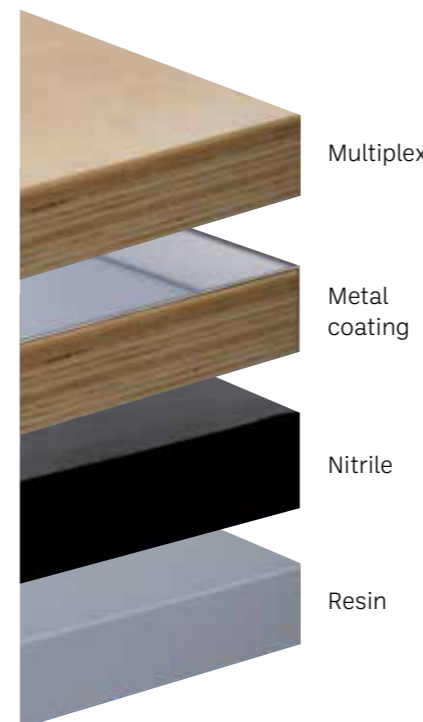

Width mm	1500	2000	2500	3000 *
Depth mm	800	800	800	800
Thick-ness mm	Art. no.	Art. no.	Art. no.	Art. no.
Multi-layer standard	-	827.409	827.412	827.414
	40	827.404 827.405***	827.410	827.454
Metal coating **	40	-	827.850	827.851
	50	-	827.853	827.854
Nitrile	43	-	827.727	827.734
	50	-	827.728	827.735
Resin	40	-	827.730	827.736
			827.742	827.742

\* In multiplex tops 3,000 mm = 2 x 1,500 mm glued.  
 \*\* Chrome-plated sheet metal cover 1.5 mm thick, folded downwards at the rear and screwed in place, open at the side; multiplex top visible.  
 \*\*\* With rear edge.



## DIMENSIONS

Installation distances with 2 or 3 brackets, with or without bases.

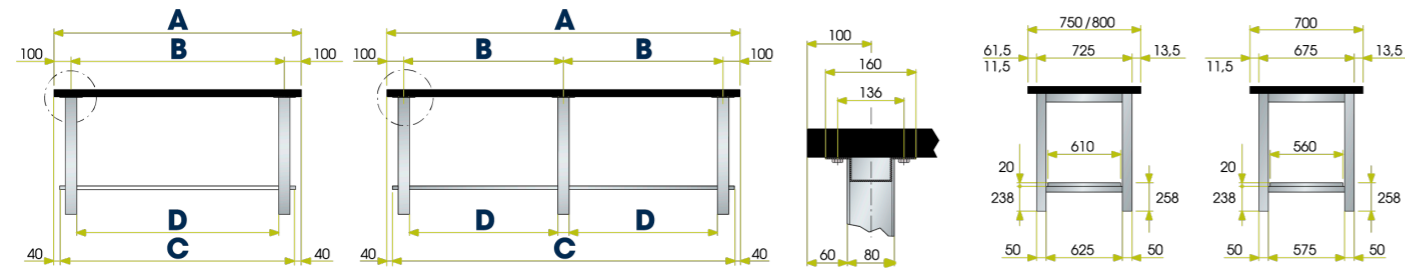

Width of the top mm	Number of brackets	Multi-layer		Nitrile		Resin	Installation width mm	Storage shelf mm	Clear width mm
		40 mm	50 mm	43 mm	50 mm	40 mm			
		A					B	C	D
1500	2	●	●	●	●	●	1300	1420	1220
2000	2	●	●	●	●	●	1800	1920	1720
2000	3	●	●	●	●	●	900	1920	820
2500	2	●	●	●	●	●	2300	2420	2220
2500	3	●	●	●	●	●	1150	2420	1070
3000*	2	●	●	●	●	●	1400	2 × 1460	1320

\* Multilayer 2 × 1500 mm glued.

● Possible  
- Partially

Installation distances with 2 or 3 brackets, with or without bases.

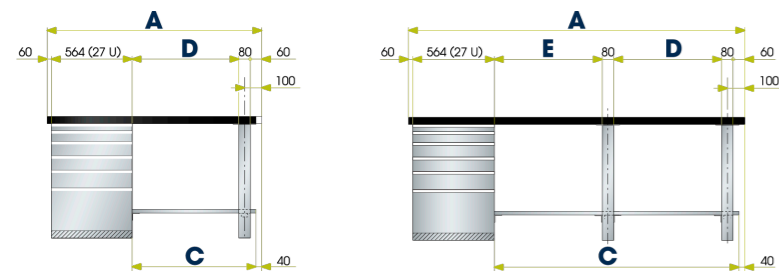

### Note

The workbenches are also available with drawer cabinets in the following dimensions:

**27 × 27 U** = 459 × 459 mm (W × D)

**27 × 36 U** = 459 × 612 mm (W × D)

**36 × 27 U** = 612 × 459 mm (W × D)

**36 × 36 U** = 612 × 612 mm (W × D)

Width of the top mm	Number of brackets	Multi-layer		Nitrile		Resin	Storage shelf mm	Clear width mm	Clear width mm
		40 mm	50 mm	43 mm	50 mm	40 mm			
		A					C	D	E
1500	1	●	●	●	●	●	835	736	-
2000	1	●	●	●	●	●	1335	1236	-
2500	1	●	●	●	●	●	1835	1736	-
2500	2	-	-	-	-	●	1835	1070	586
3000*	2	●	●	●	●	●	2335	1320	836

\* Multilayer 2 × 1500 mm glued.

● Possible  
- Partially

## LOADED

Workbench tops

Maximum load capacity on the top area. These notes apply to evenly distributed loads and static use.

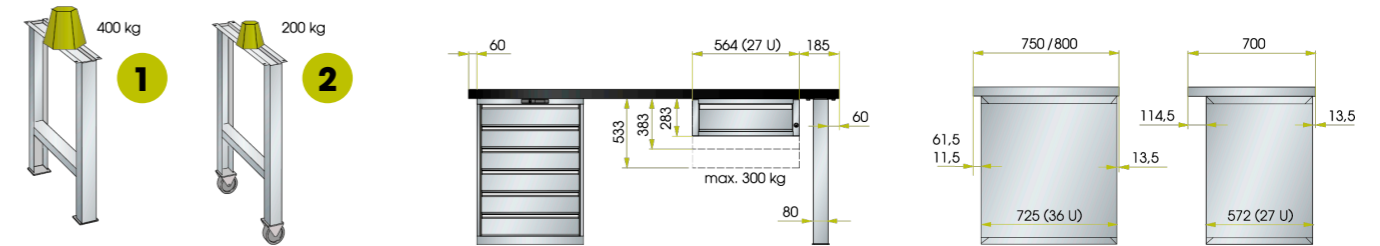

**1** The maximum load capacity is 400 kg with fixed support and 200 kg with castor support, evenly distributed loads and static use.

**2** For this version, the capacity specifications must be halved (see tables below).

Loads with support brackets or in combination with support bracket and drawer cabinets

	Thickness top mm	Width of top mm			Width of top mm			Width of top mm			Width of top mm	
		1500	2000	2500	2000	2500	3000	1500	2000	2500	2500	3000
		<b>Multi-layer</b>	40	480 kg	360 kg	500 kg	1200 kg	1050 kg	650 kg	1150 kg	800 kg	360 kg
<b>Nitrile</b>	43	410 kg	320 kg	500 kg	800 kg	680 kg	360 kg	505 kg	310 kg	320 kg	1800 kg	1100 kg
<b>Nitrile</b>	50	625 kg	450 kg	300 kg	1200 kg	1200 kg	720 kg	950 kg	600 kg	300 kg	3000 kg	1400 kg
<b>Resin</b>	40	425 kg	500 kg	500 kg	650 kg	400 kg	300 kg	500 kg	350 kg	500 kg	1100 kg	700 kg





**Perforated panels and side frames**

Fixing hooks included.

Length mm	Height mm	Art. no.
640	480	827.232
870	480	827.333
Side frame	1000	827.231



**Straight foler wholder hook (10 pcs)**

Length mm	Diameter mm	Art. no.
24	5	827.211
38	5	827.212
100	6	827.213



**Individual spring hook (10 pcs.)**

Diameter mm	Art. no.
12	827.217
18	827.318
25	827.219



**Ring hook (10 pcs.)**

Diameter mm	Art. no.
40	827.225
60	827.226
80	827.227



**Double hook (10 pcs.)**

Length mm	Diameter mm	Art. no.
38	5	827.214
100	5	827.215



**Round hooks (10 pcs.)**

Diameter mm	Art. no.
60	827.223
80	827.224



**Individual hook for tools (10 pcs)**

Length mm	Diameter mm	Art. no.
50	6	827.216



**Pair of gripper hooks (10 pcs.)**

Opening mm	Art. no.
20 - 43	827.220

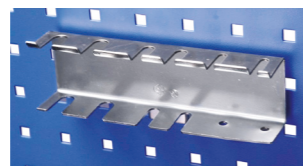

**Screwdriver rack (5 pcs)**

Length mm	Art. no.
238	827.221

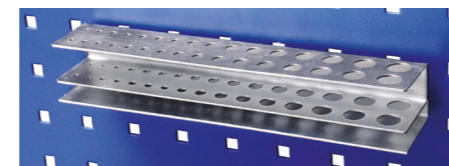

**Bit holder (5 pcs.)**

Length mm	Art. no.
238	827.234

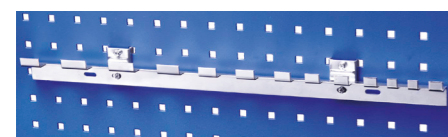

**Key rack (5 pcs)**

Length mm	Art. no.
555	827.222

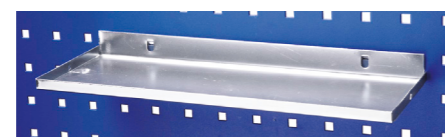

**Shelf (5 pcs)**

Length mm	Depth mm	Art. no.
350	120	827.228



For colour information, see fold-out page. When ordering, please specify the required colour (or colour combination).

# WORKSTATIONS FOR TESTING AND INSPECTION

Huni's test and inspection workstations offer optimal solutions for modern quality control. Thanks to our wide range of components, inspection stations can be configured in many different ways and adapted to individual requirements. Facilities that can comprehensively meet even the most demanding expectations. This ensures consistent quality.



**HIGH LEVEL OF DESIGN VARIETY AND MODULARITY**

For individual configuration and combination of monitor cabinets with drawers and hardware cabinets.



**MAXIMUM EASE OF USE**

With a mouse and keyboard drawer that can be fully extended and locked in an open position.



**SECURE LOCKING OPTION**

With roller shutters, drawers, monitor doors and hinged doors, which protect valuable hardware and important documentation.



**PERFECT CABLE MANAGEMENT**

Cable trays and cable passages ensure an orderly horizontal and vertical cable routing can be achieved.



**MAXIMUM STABILITY**

Thanks to the welded sheet steel construction of the highest quality.



## COMPUTER CABINETS

The computer and its hardware and software must be protected from dust, dirt and unauthorised access in the production environment. Huni's computer cabinet offers a safe and proven solution.

Equipment with:

- 1 monitor compartment with hinged door mounted on the right, with cylinder lock,
- 1 plain adjustable shelf in the monitor compartment,
- 1 x 75 mm fully extendable keyboard drawer, lockable in open position
- 1 hardware cabinet with hinged doors, including lock, robust integrated power supply, consisting of a 4-way power strip (230 V) with indicator light switch, equipment extension pull-out frame, plain adjustable shelf,
- 1 built-in fan,
- 1 power cable, length 5 m,
- 1 cable opening in the rear panel with removable cover,
- 2 push handles.

### Hinged computer cabinets mounted on the right

Static or castor version:

- With castors, rubber castors, Ø 100 mm,
- Monitor door mounted on the right,
- Usable dimensions of monitor compartment/monitor stand (W x D x H): 710 x 325 x 730 mm,
- Viewing window dimensions (W x H): 653.5 x 721 mm.

36 x 36 U W → 717 mm D ↗ 725 mm

H ↑	Description / type	Working height mm	Art. no.
1625	D / PE	880	818.014
1625	D / PE + pull-out shelf	880	818.005

### Computer cabinet accessories



#### Castors

Set of rubber castors Ø 100 mm (2 fixed and 2 swivel with brake) from fixing profiles H = 135 mm. Pre-drilled holes. Capacity 400 kg with evenly distributed load. Fastening material included.

Art. no. 822.181

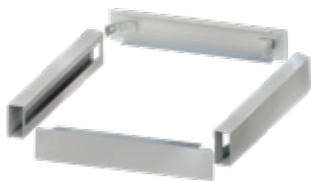

#### Bases

Base with front panels included. Pre-drilled holes. Dimensions 715 x 695 x 100 mm. Capacity 400 kg with evenly distributed load. Fastening material included.

Art. no. 806.174



#### Handles

Pair of horizontal braces made of special technopolymer, glass fibre reinforced, colour: black. Right fixing position. Holes not pre-drilled. Fastening material included.

Art. no. 822.177



#### Low pull-out shelf for CPU or printer housing

Extension 80%. Overall dimensions: 607 x 690 x 25 mm. Usable dimensions: 565 x 535 mm. Capacity 20 kg with evenly distributed load. Fastening material included.

Art. no. 818.201



#### Multi-purpose shelf

Multi-layered wooden folding ramp. Can be attached on the right or left. Usable dimensions: 450 x 620 mm - sp. 25 mm. Drilling not prepared. Load capacity 10 kg with evenly distributed load. Fastening material included.

Art. no. 827.386

For colour information, see fold-out page. When ordering, please specify the required colour (or colour combination).



- 1 Monitor stand
- 2 Handles
- 3 Document holder
- 4 Pull-out shelf
- 5 Multi-purpose shelf
- 6 Hardware cabinet
- 7 Crossbar pairs on castors
- 8 Ventilator fans



#### Document holder

The base is adjustable. Can be attached on the right or left. Usable dimensions 600 x 50 mm. Pre-drilled holes. Fastening material included

Art. no. 822.129

## QUALITY STATION

### Compliance with quality standards

Born from the need to monitor and verify the various processes in the production area - the Quality Centre - is a real quality control station, where the operator can easily perform all activities to ensure compliance with certain quality standards.

The Quality Station is the perfect solution for the execution, recording and archiving of inspection procedures in the production process and can be flexibly adapted. This allows secure storage of documents, minutes and hardware.

- Computer station with lockable hinged doors, shelf pull-out fan and 3 sockets
- 3 telescopic drawers, fully extendable (each with front height 300 mm; load capacity 75 KG), with additional hanging folder holder
- Modular stacking cabinet with plastic and lockable roller shutter
- Locks with removable cylinder

### Composition

Upper part - On request, sold separately

- 1 Lockable plastic roller shutter
- 2 Adjustable shelves 1385x300 mm, height adjustable, 25 mm grid
- 1 LED lamp x 30 W
- 5 Sockets 230 V - 16 A (PE)
- 1 Switch for illumination
- 1 Pull-out countertop, bilaminated, pale grey 1370x 645 mm - thickness 29 mm, with backgauge  
Top extension of 150 mm with stopper for rear anchoring  
Integrated electrical system and power cables

### Lower part

- Computer workstation with lockable hinged doors, pull-out shelf
- Fan and 3 sockets 16 A - 230 V (PE) equipped with a 5-meter-long cable
- 4 Telescopic drawers, fully extendable (each with front height 300 mm; load capacity 75 KG), with additional hanging folder holder

2 x 36 x 36 U W → 1434 mm D ↗ 725 mm

H ↑	Description / type	Working height mm	Drawers mm	Pull-out shelf for appliances	Art. no.
2200	D/PE	1020	3 x 300*	1	818.008
2200	D/PE	1050	-	1	818.100

\* Capacity 75 kg. Includes 3 pairs of folder holders.



- 1 Quality module
- 2 Hard laminate top
- 3 Drawer units
- 4 Hardware cabinet

Partition material for drawers from page 104.



# COMPLETION OPTIMAL



## HIGH STORAGE CAPACITY

Maximum usable space thanks to sophisticated design.



## MAXIMUM EASE OF USE

Thanks to individually height-adjustable shelves.



## SECURE LOCK

Standard KEY-Lock locking system with exchangeable cylinder or individual locking concepts.



## HIGHLY STABLE

Thanks to the housing structure with a load-bearing capacity of up to 200 kg.



## COMPLETELY LOW-NOISE SLIDING

Of the sliding doors or pull-out shelves.

Huni's wide range of cabinets ensures you can specifically integrate the furnishings for your company and warehouse. The high-quality steel cabinets can be flexibly integrated into a wide range of work environments and adapted to individual requirements. They are suitable for industrial applications as well as for storing documents and the like in offices and for administrative purposes. Of course, your personal belongings are also always in good hands in a Huni cabinet.





# CABINET SOLUTION

## VERTICAL DRAWER CABINETS

Huni vertical drawer cabinets offer space-saving storage where space is at a premium: tools, work materials and more. The vertical drawers can be used on both sides and are available either with pegboards or with shelves for the purpose of holding Huni containers, tools, documents and NC tool holders. The result: maximum storage capacity on a minimum installation area. That's what we call efficiency.



### FLEXIBLE EQUIPMENT OPTIONS

With adjustable shelves, pegboards and shelves for tool holder for NC storage in a 50 mm grid.



### LOW-NOISE SLIDING

Even with heavy loads, thanks to a telescopic extension mechanism on smooth-running rubber castors.



### OUTSTANDING PROTECTION

Resistant to dirt, liquids and mechanical stress thanks to closed cabinet housing with impact-resistant and wear-resistant surfaces.



### MAXIMUM EASE OF USE

Thanks to direct access, on both sides, to the tools and small parts.



### MAXIMUM STABILITY

With a cabinet load capacity of up to 1000 kg.



### HIGH LOAD CAPACITY

Vertical pull-out drawers with load capacity of up to 200 kg.

**H** 1950 mm **W** 1000 mm **D** 695 mm



Equipment Vertical drawers Art. no.

#### Cabinet with vertical drawers and adjustable shelves

3 or 4 pull-out drawers with 4 plain adjustable shelves, usable dimensions: W 291/210 x D 584 x H 25 mm	3	200	KEY Lock	818.1027
	4	200	KEY Lock	818.1028



#### Cabinet with vertical drawers and pegboards

3 or 4 pull-out drawers with pegboards, H 1700 x D 612 mm, double-sided	3	200	KEY Lock	818.1029
	4	200	KEY Lock	818.1030



Art. no. **818.1028**  
Front panels in pale blue, RAL 5012  
(excl. containers for storage)



# CABINET SOLUTION

## LIQUID CABINETS AND CORNER CABINET

Huni cabinets for chemicals and liquids are suitable for the safe and prescribed storage of water pollutants with pollution class WGK 1 - 3. Liquids that are used in the daily production cycle are well stored in Huni liquid cabinets. Canisters can be placed on the pull-out shelves, and any liquid drips that may fall are collected in suitable tubs.



### SAFE AND CLEAN STORAGE

Using a recovery tub with liquid-tight welding in accordance with Water Protection Act § 19/StawaR.



### CAN BE ADAPTED TO NEW ARTICLES STORED

thanks to the flexibility of installing and repositioning the spill pallet and canister shelf in 25 mm grids.



### SECURE LOCK

With solid sheet doors (integrated, bevelled on one part) and locking systems available.



### MAXIMUM STABILITY

With a cabinet load capacity of up to 500 kg.

## LIQUID CABINET

The cabinets are equipped with: chrome-plated recovery tub, 2 mm thickness, liquid-tight welding in accordance with the Water Protection Act § 19/StawaR, 40-litre capacity, powder-coated shelves according to colour chart, high-density polyethylene canisters with high-gloss chrome-plated drain tap. Solid sheet doors, bevelled on one part, with pintal bearing assembly, 235-degree opening angle.

**H** ↑ 717 mm    **W** → 753 mm    **D** ↗ 1450 mm

Equipment	Door support	kg	Lock	Art. no.
<b>Cabinets with 2 solid sheet hinged doors</b>				
2 canister shelf 8 x 25 l canisters 1 drip tub Tub dimensions: 651 x 620 x 100 mm (W x D x H)	Tightening pins	200	KEY Lock	806.545
3 canister shelf 10 x 10 l canisters 4 x 25 l canisters 1 drip tub Tub dimensions: 651 x 620 x 100 mm (W x D x H)	Tightening pins	200	KEY Lock	806.546



### Canister with drain tap

With screw cap. Filter in filler neck. High-gloss chrome-plated drain tap with seal. Description: high density polyethylene, transparent.

Width mm	Depth mm	Height mm	Capacity	Art. no.
120	440	270	10 l	828.340
150	440	490	25 l	828.341



### Canister shelf

The canister shelf has a handle at the left and right ends and an intermediate stopper. It has a depth of only 27 U (451 mm) so that there is enough space for the canister tap on the front.

Art. no. 818.204



Caution: not suitable for storage of hazardous flammable materials.

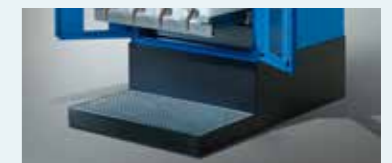

### Bracket with drip tub

The collection tub of the cabinet for liquids is in accordance with the Water Protection Act. Hermetically welded and has a test certificate. It has a capacity of 40 l.

Art. no. 818.205

## CORNER CABINETS

Structure of a sheet steel, powder-coated according to the colour chart. The countersunk shelf can be removed. Double-leaf doors with an interlocking lock and safety cylinder. The lock protrudes 20 mm at the front.

**H** ↑ 1000 mm    **W** → 1202 mm    **D** ↗ 725 mm

Equipment	kg	Lock	Art. no.
1 adjustable shelf	100	KEY Lock	818.004



### Bases for corner cabinets

Made of sheet steel, powder coating according to colour chart. The bases are screwed to the base of the cabinets. Fastening material included.



Art. no.	818.206	818.207
Dimensions (W x D x H mm)	1202 x 723 x 50	1202 x 723 x 100



# ORDER FOR YOUR SUCCESS



## WIDE RANGE OF EQUIPMENT AND MODULARITY

With pre-configured sets and freely combinable separate components such as slotted panels, dividers, trays, troughs, etc.



## SIMPLE AND QUICK TO ASSEMBLE

The all-round drawer slots and perforated drawer bottoms can be used to mount and fix the slotted walls, dividers, cutter holders and fastening pins.



## HIGHLY COMBINABLE

With the entire Huni range thanks to a single standard size.

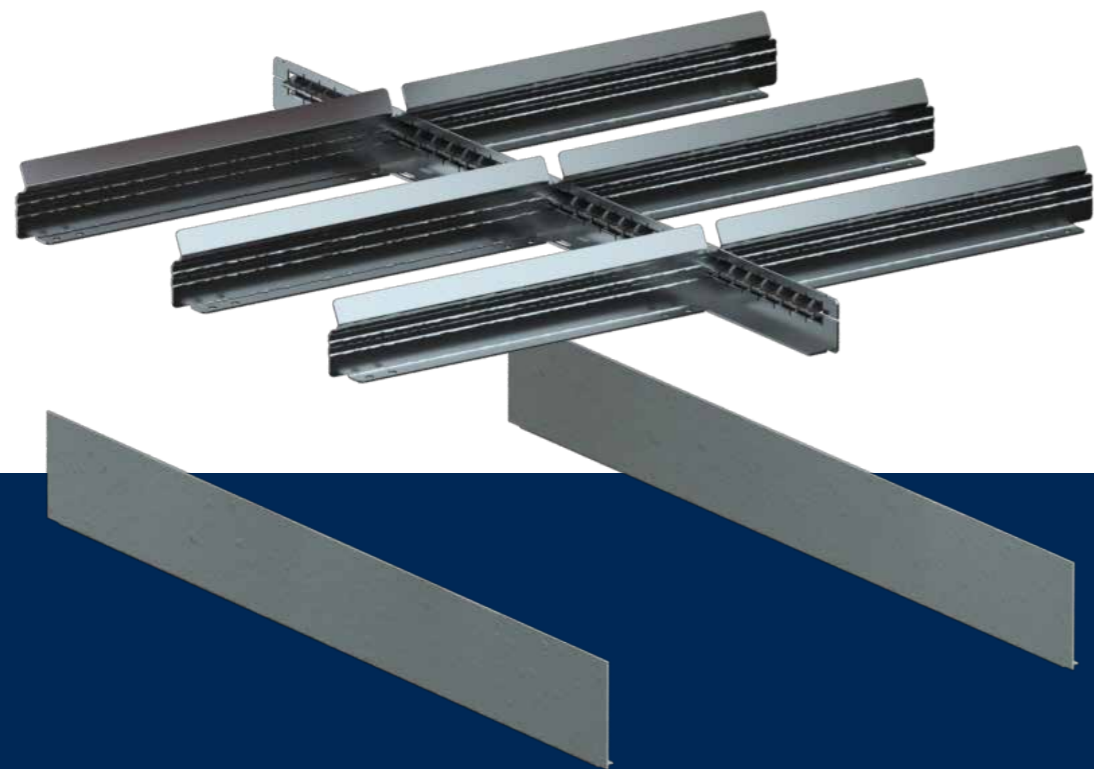

The drawer partition material from Huni systematically ensures order in every sector and for every requirement. From small parts to NC tools, our trays, troughs, dividers and more offer flexible solutions for storing virtually any article. The result is clear: systematic ordering reduces search times, simplifies work processes and thus ensures efficient results.





## ONE SYSTEM, MULTIPLE POSSIBILITIES

Thanks to Huni's measuring system, our partition material can be freely combined and is compatible with the entire Huni range. This means that you can store any article you wish to store, either loose or in pre-configured sets.

## THE HUNI UNITS (U), THE INTELLIGENT MEASURING SYSTEM

Thanks to their practical modular size, Huni (U) units ensure a clear match between body, drawer and partition material. **One Huni unit (U) is 17 mm** and is based on modularity for drawer partitioning. The drawer bodies and drawers for these drawers have the same number of Huni units, although they have different sizes. **Selection of suitable partition material:**

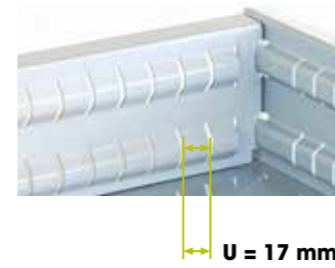

- 1 Determining drawer size in Huni units (U).
- 2 Determining the size of the set or separate components in Huni units (U).
- 3 The sum of the units of the separate components must not exceed the sum of the drawer units. Depending on the material to be stored, calculate the drawer's usable height.

## WIDE RANGE OF EQUIPMENT AND MODULARITY

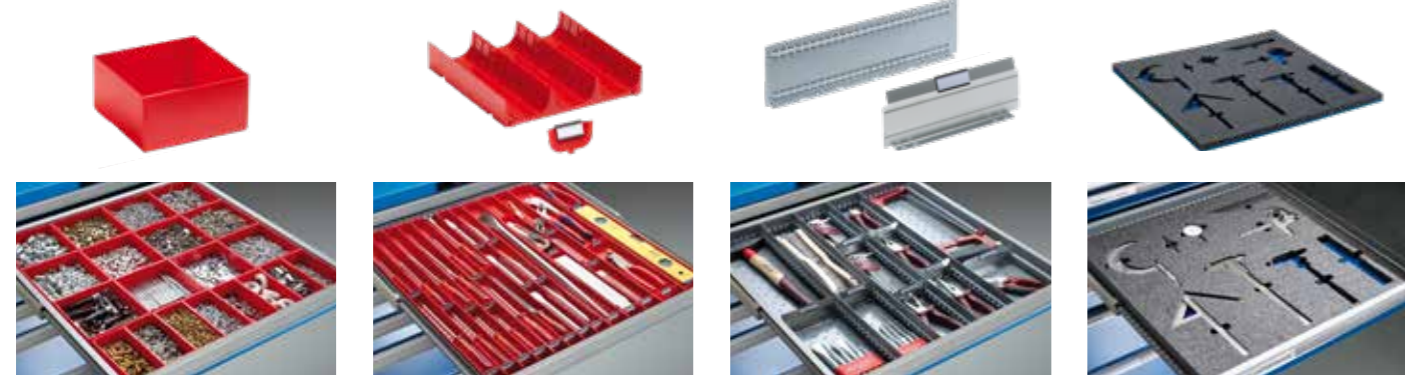

### Trays

- Ideal for small parts of different sizes.
- Also available in ESD version.

### Trough

- For storage of cylindrical articles.
- Can be divided into lengths as required.

### Slotted walls and dividers

- For flexible subdivision.
- For different sized articles.

### PE foam inserts

- For orderly and precise storage of tools.
- They provide a secure hold in the drawer.
- Available with blue brackets.



### Fastening pins and anti-slide mats

- Ideal for larger objects.



### NC tool holder bracket

- For neat and visible NC storage.

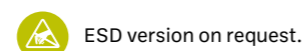

ESD version on request.



NC storage and transport unit see page 70.

## 27 x 27 E 459 x 459 mm

Trough		Trough		Trough		Trays	
By height Front mm	Art. no.	By height Front mm	Art. no.	By height Front mm	Art. no.	By height Front mm	Art. no.
50	803.193	50	803.194	50	803.195	50	803.196
9 troughs:	4-part, Ø 33 mm*	9 troughs:	3-part, Ø 45 mm*	9 troughs:	2-part, Ø 70 mm*	75	803.207
40 trough separators:	4-part, Ø 33 mm*	30 trough separators:	3-part, Ø 45 mm*	20 trough separators:	2-part, Ø 70 mm*	24 trays:	75 x 75 mm
						6 trays:	150 x 150 mm

\* Depending on the material to be stored, calculate the usable height of the drawer.

Trays		Trays		Slotted walls and dividers		Slotted walls and dividers	
By height Front mm	Art. no.	By height Front mm	Art. no.	By height Front mm	Art. no.	By height Front mm	Art. no.
50	803.197	50	803.198	50	803.264	50	803.268
75	803.208	75	803.209	75	803.265	75	803.269
100, 125	803.227	100, 125	803.228	100, 125	803.266	100, 125	803.270
18 trays:	150 x 75 mm	9 trays:	150 x 150 mm	150	803.267	150	803.271
				3 slotted walls:	27 U	200	803.272
				9 dividers:	6 U	250	803.273
				2 dividers:	9 U	300	803.274
						2 slotted walls:	27 U
						9 dividers:	9 U

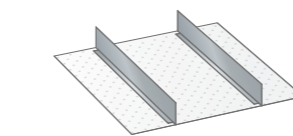

### Dividers

By height Front mm	Art. no.
75	803.285
100, 125	803.286
150	803.287
200	803.288
250	803.289
2 dividers:	27 U

**Countersink partition material correctly**

The troughs should always be installed in the sliding direction of the drawers, otherwise round components such as drill bits or similar could fall out if the drawers are locked forcefully.



**36 x 27 E** 612 x 459 mm

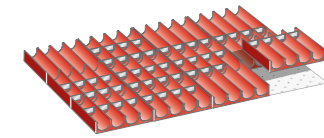

**Trough**

By height Front mm	Art. no.
50	<b>804.180</b>
12 troughs:	4-part, Ø 33 mm*
50 trough separators:	4-part, Ø 33 mm*

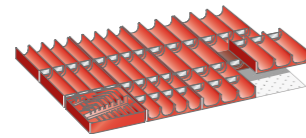

**Troughs and allen key insert**

By height Front mm	Art. no.
50	<b>805.200</b>
5 troughs:	4-part, Ø 33 mm*
20 trough separators:	4-part, Ø 33 mm*
6 troughs:	3-part, Ø 45 mm*
20 trough separators:	3-part, Ø 45 mm*
1 allen key insert	

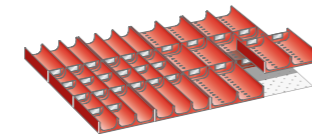

**Trough**

By height Front mm	Art. no.
50	<b>805.201</b>
6 troughs:	3-part, Ø 45 mm*
20 trough separators:	3-part, Ø 45 mm*
6 troughs:	2-part, Ø 70 mm*
10 trough separators:	2-part, Ø 70 mm*

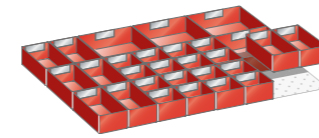

**Trays**

By height Front mm	Art. no.
75	<b>805.202</b>
16 trays:	75 x 75 mm
8 trays:	150 x 75 mm
4 trays:	150 x 150 mm

\* Depending on the material to be stored, calculate the usable height of the drawer.

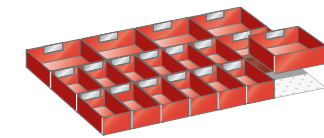

**Trays**

By height Front mm	Art. no.
50	<b>804.188</b>
75	<b>804.201</b>
100, 125	<b>804.220</b>
12 trays:	150 x 75 mm
6 trays:	150 x 150 mm

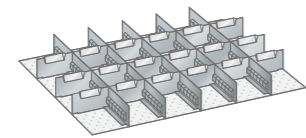

**Slotted walls and dividers**

By height Front mm	Art. no.
50	<b>805.293</b>
75	<b>805.294</b>
100, 125	<b>805.295</b>
150	<b>805.296</b>
5 slotted walls:	27 U
18 dividers:	6 U

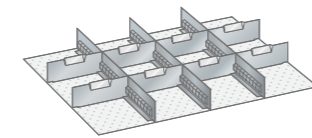

**Slotted walls and dividers**

By height Front mm	Art. no.
50	<b>805.198</b>
75	<b>805.203</b>
100, 125	<b>805.220</b>
150	<b>805.240</b>
200	<b>805.260</b>
250	<b>805.273</b>
3 slotted walls:	27 U
8 dividers:	9 U

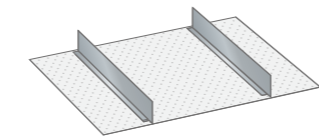

**Dividers**

By height Front mm	Art. no.
75	<b>805.204</b>
100, 125	<b>805.221</b>
150	<b>805.241</b>
200	<b>805.261</b>
250	<b>805.280</b>
2 dividers:	27 U

**Note**

The front height is the same as the height of the drawer front. See pages 116 /118 for actual height of partition material.

Excluding partition material set.

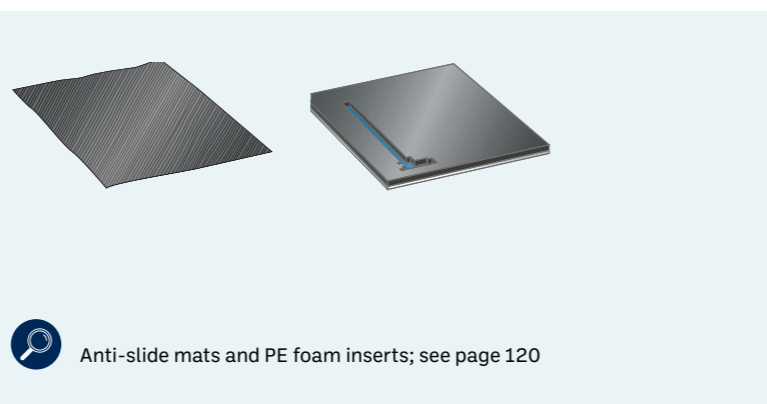

Anti-slide mats and PE foam inserts; see page 120

**54 x 27 E** 918 x 459 mm

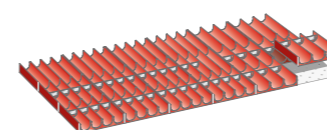

**Trough**

By height Front mm	Art. no.
75	<b>809.180</b>
12 troughs:	4-part, Ø 33 mm*
30 trough separators:	4-part, Ø 33 mm*
6 troughs:	3-part, Ø 45 mm*
10 trough separators:	3-part, Ø 45 mm*

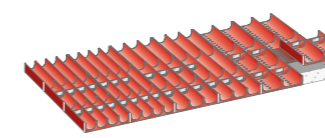

**Trough**

By height Front mm	Art. no.
75, 100, 125	<b>809.181</b>
6 troughs:	4-part, Ø 33 mm*
20 trough separators:	4-part, Ø 33 mm*
6 troughs:	3-part, Ø 45 mm*
10 trough separators:	3-part, Ø 45 mm*
6 troughs:	2-part, Ø 70 mm*
10 trough separators:	2-part, Ø 70 mm*

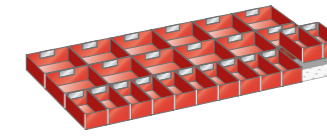

**Trays**

By height Front mm	Art. no.
50	<b>809.182</b>
75	<b>809.200</b>
100, 125	<b>809.220</b>
12 trays:	150 x 75 mm
12 trays:	150 x 150 mm

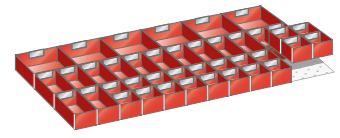

**Trays**

By height Front mm	Art. no.
50	<b>809.183</b>
75	<b>809.201</b>
20 trays:	75 x 75 mm
14 trays:	150 x 75 mm
6 trays:	150 x 150 mm

\* Depending on the material to be stored, calculate the usable height of the drawer.

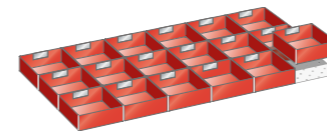

**Trays**

By height Front mm	Art. no.
50	<b>809.184</b>
75	<b>809.202</b>
100, 125	<b>809.221</b>
18 trays:	150 x 150 mm

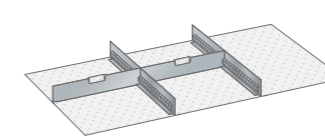

**Slotted walls and dividers**

By height Front mm	Art. no.
50	<b>809.186</b>
75	<b>809.204</b>
100, 125	<b>809.223</b>
150	<b>809.240</b>
200	<b>809.260</b>
250	<b>809.280</b>
300	<b>809.300</b>
2 slotted walls:	27 U
2 dividers:	18 U

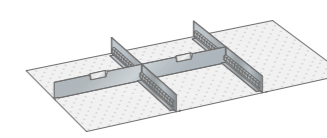

**Slotted walls and dividers**

By height Front mm	Art. no.
50	<b>809.187</b>
75	<b>809.205</b>
100, 125	<b>809.224</b>
150	<b>809.241</b>
200	<b>809.261</b>
250	<b>809.281</b>
300	<b>809.301</b>
3 slotted walls:	27 U
3 dividers:	12 U

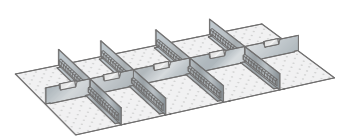

**Slotted walls and dividers**

By height Front mm	Art. no.
50	<b>809.188</b>
75	<b>809.206</b>
100, 125	<b>809.225</b>
150	<b>809.242</b>
200	<b>809.262</b>
250	<b>809.282</b>
300	<b>809.302</b>
4 slotted walls:	27 U
2 dividers:	9 U
3 dividers:	12 U



54 x 27 E 918 x 459 mm

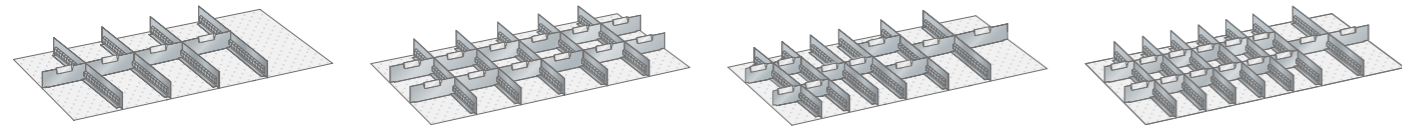

**Slotted walls and dividers**

By height Front mm	Art. no.
50	809.189
75	809.207
100, 125	809.226
150	809.243
200	809.263
250	809.283
300	809.303
4 slotted walls:	27 U
4 dividers:	18 U

**Slotted walls and dividers**

By height Front mm	Art. no.
50	809.190
75	809.208
100, 125	809.227
150	809.244
200	809.264
250	809.284
300	809.304
5 slotted walls:	27 U
12 dividers:	9 U

**Slotted walls and dividers**

By height Front mm	Art. no.
50	809.191
75	809.209
100, 125	809.228
6 slotted walls:	27 U
6 dividers:	6 U
3 dividers:	12 U
1 dividers:	9 U

**Slotted walls and dividers**

By height Front mm	Art. no.
50	809.290
75	809.291
100, 125	809.292
7 slotted walls:	27 U
12 dividers:	6 U
2 dividers:	9 U

27 x 36 E 459 x 612 mm



**Trough**

By height Front mm	Art. no.
50	804.180
12 troughs:	4-part, Ø 33 mm*
50 trough separators:	4-part, Ø 33 mm*

**Trough**

By height Front mm	Art. no.
50	804.181
4 troughs:	4-part, Ø 33 mm*
20 trough separators:	4-part, Ø 33 mm*
8 troughs:	3-part, Ø 45 mm*
10 trough separators:	3-part, Ø 45 mm*

**Trough**

By height Front mm	Art. no.
50	804.182
4 troughs:	3-part, Ø 45 mm*
20 trough separators:	3-part, Ø 45 mm*
8 troughs:	2-part, Ø 70 mm*
10 trough separators:	2-part, Ø 70 mm*

**Trays**

By height Front mm	Art. no.
50	804.186
16 trays with centre partition:	75 x 75 mm
16 trays:	75 x 75 mm
4 trays:	150 x 75 mm
2 trays:	150 x 150 mm

\* Depending on the material to be stored, calculate the usable height of the drawer.

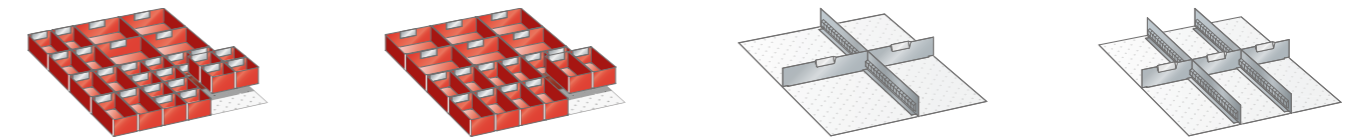

**Trays**

By height Front mm	Art. no.
50	804.187
75	804.200
16 trays:	75 x 75 mm
8 trays:	150 x 75 mm
4 trays:	150 x 150 mm

**Trays**

By height Front mm	Art. no.
50	804.188
75	804.201
100, 125	804.220
12 trays:	150 x 75 mm
6 trays:	150 x 150 mm

**Slotted walls and dividers**

By height Front mm	Art. no.
75	804.199
100, 125	804.286
150	804.287
200	804.272
250	804.273
1 slotted walls:	36 U
1 dividers:	12 U
2 dividers:	15 U

**Slotted walls and dividers**

By height Front mm	Art. no.
75	804.202
100, 125	804.221
150	804.240
200	804.260
250	804.280
2 slotted walls:	36 U
3 dividers:	9 U

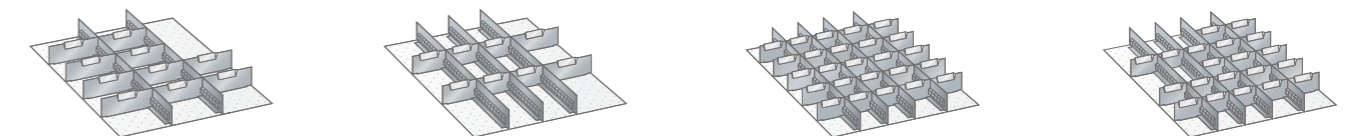

**Slotted walls and dividers**

By height Front mm	Art. no.
50	804.189
75	804.203
100, 125	804.222
150	804.241
2 slotted walls:	36 U
10 dividers:	9 U

**Slotted walls and dividers**

By height Front mm	Art. no.
50	804.190
75	804.204
100, 125	804.223
150	804.242
3 slotted walls:	36 U
6 dividers:	6 U
2 dividers:	9 U

**Slotted walls and dividers**

By height Front mm	Art. no.
50	804.192
75	804.206
100, 125	804.225
4 slotted walls:	36 U
15 dividers:	5 U
10 dividers:	6 U

**Slotted walls and dividers**

By height Front mm	Art. no.
50	804.191
75	804.205
100, 125	804.224
4 slotted walls:	36 U
5 dividers:	4 U
5 dividers:	5 U
10 dividers:	6 U





**27 x 36 E** 459 x 612 mm

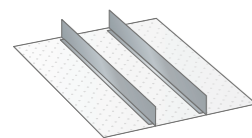

**Dividers**

By height Front mm	Art. no.
75	<b>804.288</b>
100, 125	<b>804.289</b>
150	<b>843.290</b>
200	<b>804.261</b>
250	<b>804.281</b>
2 dividers:	36 U

**36 x 36 E** 612 x 612 mm

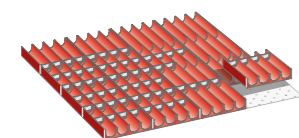

**Trough**

By height Front mm	Art. no.
50	<b>806.180</b>
16 troughs:	4-part, Ø 33 mm*
64 trough separators:	4-part, Ø 33 mm*

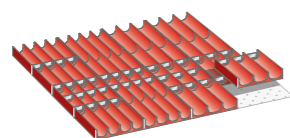

**Trough**

By height Front mm	Art. no.
50	<b>806.181</b>
8 troughs:	4-part, Ø 33 mm*
54 trough separators:	4-part, Ø 33 mm*
8 troughs:	3-part, Ø 45 mm*
16 trough separators:	3-part, Ø 45 mm*

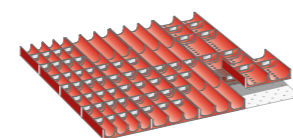

**Trough**

By height Front mm	Art. no.
50	<b>806.182</b>
4 troughs:	4-part, Ø 33 mm*
30 trough separators:	4-part, Ø 33 mm*
8 troughs:	3-part, Ø 45 mm*
20 trough separators:	3-part, Ø 45 mm*
4 troughs:	2-part, Ø 70 mm*
10 trough separators:	2-part, Ø 70 mm*

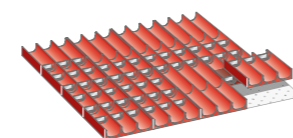

**Trough**

By height Front mm	Art. no.
50	<b>806.183</b>
16 troughs:	3-part, Ø 45 mm*
51 trough separators:	3-part, Ø 45 mm*

\* Depending on the material to be stored, calculate the usable height of the drawer.

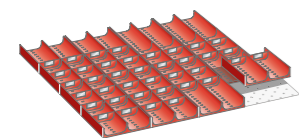

**Trough**

By height Front mm	Art. no.
50	<b>806.184</b>
16 troughs:	2-part, Ø 70 mm*
38 trough separators:	2-part, Ø 70 mm*

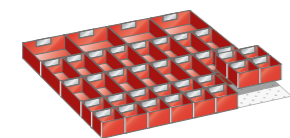

**Trays**

By height Front mm	Art. no.
50	<b>806.186</b>
75	<b>806.200</b>
16 trays:	75 x 75 mm
16 trays:	150 x 75 mm
4 trays:	150 x 150 mm

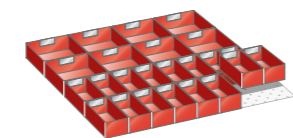

**Trays**

By height Front mm	Art. no.
50	<b>806.187</b>
75	<b>806.201</b>
100, 125	<b>806.220</b>
16 trays:	150 x 75 mm
8 trays:	150 x 150 mm

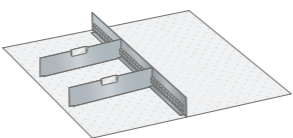

**Slotted walls and dividers**

By height Front mm	Art. no.
100, 125	<b>806.270</b>
150	<b>806.271</b>
200	<b>806.272</b>
250	<b>806.273</b>
300	<b>806.274</b>
1 slotted walls:	36 U
2 dividers:	18 U

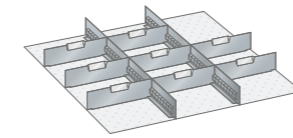

**Slotted walls and dividers**

By height Front mm	Art. no.
75	<b>806.209</b>
100, 125	<b>806.286</b>
150	<b>806.287</b>
200	<b>806.288</b>
2 slotted walls:	36 U
8 dividers:	12 U

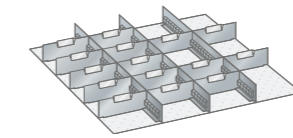

**Slotted walls and dividers**

By height Front mm	Art. no.
75	<b>806.202</b>
100, 125	<b>806.223</b>
150	<b>806.242</b>
200	<b>806.263</b>
250	<b>806.283</b>
3 slotted walls:	36 U
14 dividers:	9 U

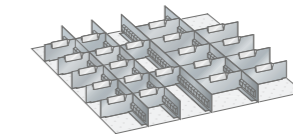

**Slotted walls and dividers**

By height Front mm	Art. no.
50	<b>806.189</b>
75	<b>806.203</b>
100, 125	<b>806.224</b>
150, 175	<b>806.243</b>
4 slotted walls:	36 U
12 dividers:	6 U
6 dividers:	9 U

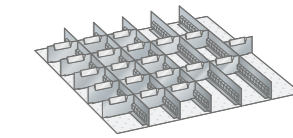

**Slotted walls and dividers**

By height Front mm	Art. no.
50	<b>806.190</b>
75	<b>806.204</b>
100, 125	<b>806.225</b>
5 slotted walls:	36 U
22 dividers:	6 U

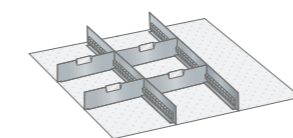

**Slotted walls and dividers**

By height Front mm	Art. no.
100, 125	<b>806.221</b>
150, 175	<b>806.240</b>
200	<b>806.261</b>
250	<b>806.281</b>
300, 450	<b>806.301</b>
2 slotted walls:	36 U
4 dividers:	12 U

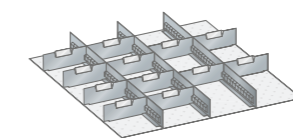

**Slotted walls and dividers**

By height Front mm	Art. no.
100, 125	<b>806.222</b>
150, 175	<b>806.241</b>
200	<b>806.262</b>
250	<b>806.282</b>
3 slotted walls:	36 U
8 dividers:	8 U
4 dividers:	10 U

**54 x 36 E** 918 x 612 mm

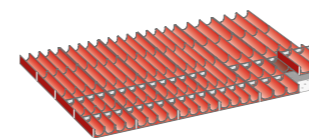

**Trough**

By height Front mm	Art. no.
50	<b>810.180</b>
16 troughs:	4-part, Ø 33 mm*
30 trough separators:	4-part, Ø 33 mm*
8 troughs:	3-part, Ø 45 mm*
10 trough separators:	3-part, Ø 45 mm*

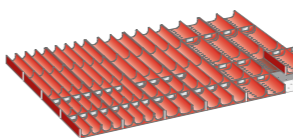

**Trough**

By height Front mm	Art. no.
50	<b>810.181</b>
8 troughs:	4-part, Ø 33 mm*
15 trough separators:	4-part, Ø 33 mm*
8 troughs:	3-part, Ø 45 mm*
10 trough separators:	3-part, Ø 45 mm*
8 troughs:	2-part, Ø 70 mm*
6 trough separators:	2-part, Ø 70 mm*

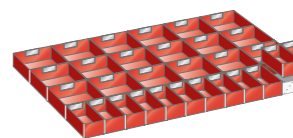

**Trays**

By height Front mm	Art. no.
50	<b>810.182</b>
75	<b>810.200</b>
100, 125	<b>810.220</b>
12 trays:	150 x 75 mm
18 trays:	150 x 150 mm

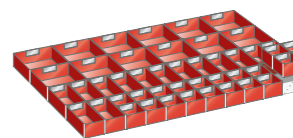

**Trays**

By height Front mm	Art. no.
50	<b>810.183</b>
75	<b>810.201</b>
20 trays:	75 x 75 mm
14 trays:	150 x 75 mm
12 trays:	150 x 150 mm

\* Depending on the material to be stored, calculate the usable height of the drawer.

**54 x 36 E** 918 x 612 mm

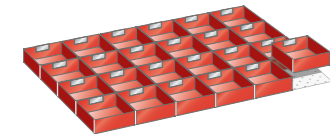

**Trays**

By height Front mm	Art. no.
50	810.184
75	810.202
100, 125	810.221

16 trays: 150 x 150 mm

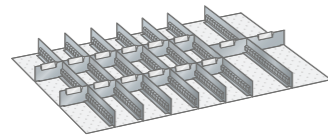

**Slotted walls and dividers**

By height Front mm	Art. no.
50	810.192
75	810.291
100, 125	810.292

7 slotted walls: 36 U  
12 dividers: 6 U  
2 dividers: 9 U

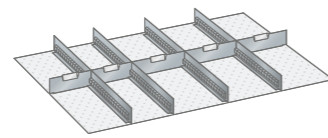

**Slotted walls and dividers**

By height Front mm	Art. no.
50	810.188
75	810.206
100, 125	810.225
150	810.242
200	810.262
250	810.282
300	810.302

4 slotted walls: 36 U  
2 dividers: 9 U  
3 dividers: 12 U

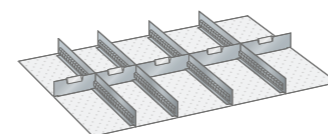

**Slotted walls and dividers**

By height Front mm	Art. no.
50	810.189
75	810.207
100, 125	810.226
150	810.243
200	810.263
250	810.283
300	810.303

4 slotted walls: 36 U  
4 dividers: 9 U

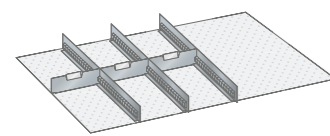

**Slotted walls and dividers**

By height Front mm	Art. no.
50	810.187
75	810.205
100, 125	810.224
150	810.241
200	810.261
250	810.281
300	810.301

3 slotted walls: 36 U  
3 dividers: 12 U

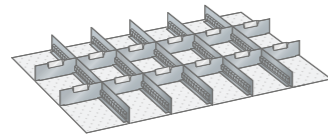

**Slotted walls and dividers**

By height Front mm	Art. no.
50	810.190
75	810.208
100, 125	810.227
150	810.244
200	810.264
250	810.284
300	810.304

5 slotted walls: 36 U  
12 dividers: 9 U

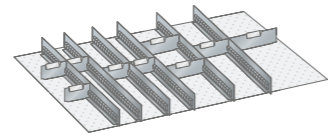

**Slotted walls and dividers**

By height Front mm	Art. no.
50	810.191
75	810.209
100, 125	810.228

6 slotted walls: 36 U  
6 dividers: 2 U  
3 slotted walls: 9 U  
1 dividers: 12 U

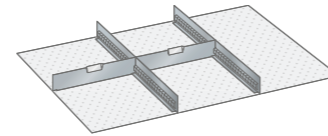

**Dividers**

By height Front mm	Art. no.
50	810.186
75	810.204
100, 125	810.223
150	810.240
200	810.260
250	810.280
300	810.300

2 dividers: 36 U  
2 dividers: 18 U

**64 x 36 E** 1088 x 612 mm

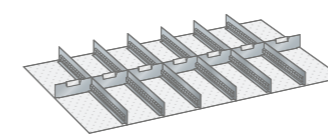

**Slotted walls and dividers**

By height Front mm	Art. no.
50	812.180
75	812.199
100, 125	812.240

6 slotted walls: 36 U  
6 dividers: 9 U  
1 dividers: 10 U

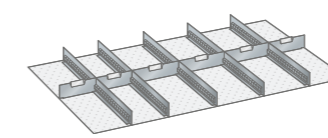

**Slotted walls and dividers**

By height Front mm	Art. no.
50	812.181
75	812.221
100, 125	812.241

5 slotted walls: 36 U  
2 dividers: 9 U  
3 dividers: 12 U  
1 dividers: 10 U

**78 x 36 E** 1326 x 612 mm

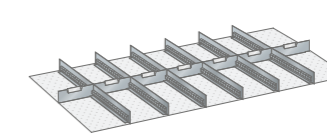

**Slotted walls and dividers**

By height Front mm	Art. no.
50	814.200
75	814.220
100, 125	814.240

6 slotted walls: 36 U  
4 dividers: 9 U  
2 dividers: 12 U  
1 dividers: 18 U

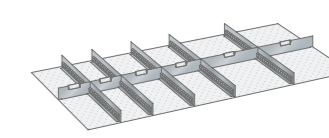

**Slotted walls and dividers**

By height Front mm	Art. no.
50	814.201
75	814.221
100, 125	814.241

5 slotted walls: 36 U  
2 dividers: 9 U  
2 dividers: 12 U  
2 dividers: 18 U

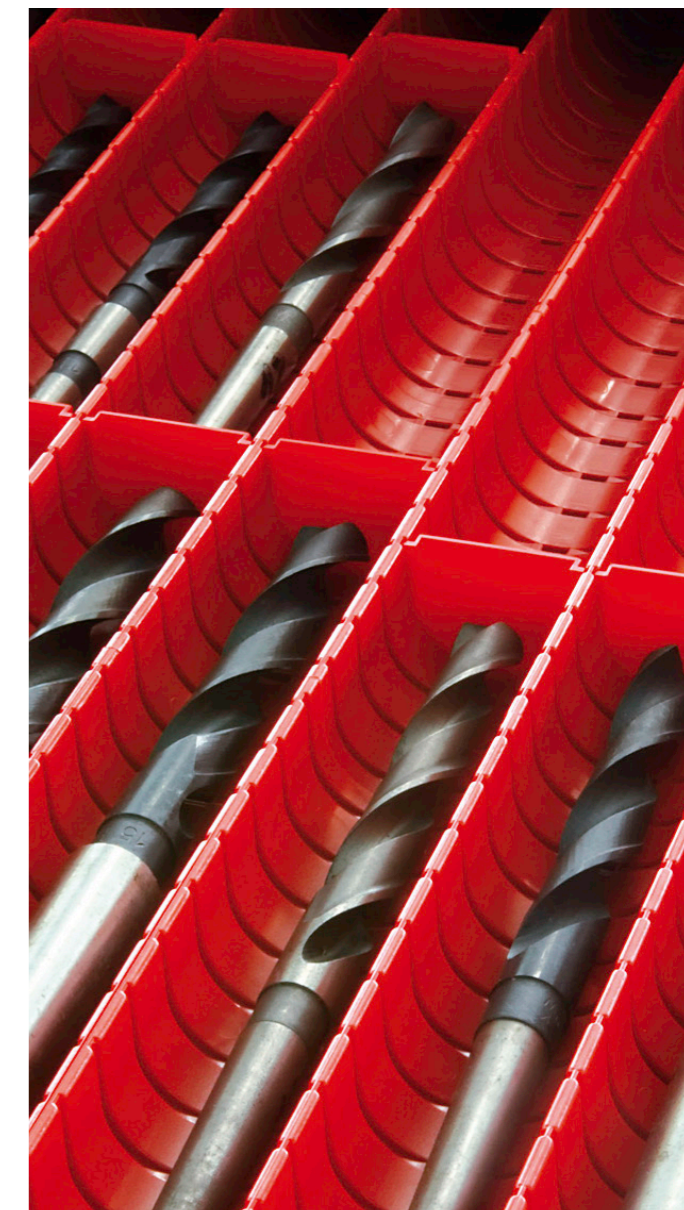



**Slotted walls, double-sided**

- For lengthwise and transverse dividing of drawers in combination with dividers. Description: sheet steel.

**Dividers, smooth**

- For dividing drawers lengthwise and transverse. Description: sheet steel.

**Dividers**

- In combination with the slotted walls, they allow drawers to be precisely divided as required. Description: aluminium.

**What is the purpose of the slotted panels and dividers in the Huni drawers?**

Example: for drawer unit 36 x 36 E (612 x 612 mm)

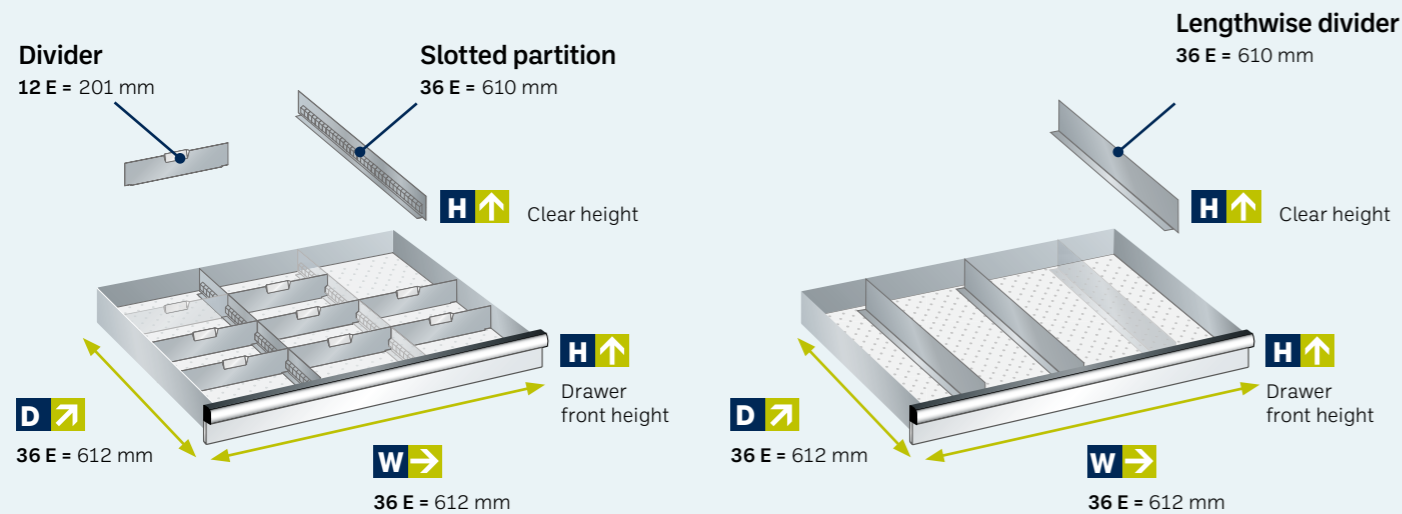

**Label holders for slotted walls, dividers, trays and troughs including labels.**

Label size (W x H) mm	Number	Art. no.
29.5 x 15.4	1	828.161
42 x 15.4	1	828.181
50 x 15.4	1	828.162
29.5 x 15.4	10	828.164
42 x 15.4	10	828.182
50 x 15.4	10	828.165



Front height of drawer	50 mm	75 mm	100, 125 mm	150 mm	200 mm	250 mm	300 mm
Clear height	31.5 mm	50 mm	75 mm	125 mm	175 mm	225 mm	275 mm

**Slotted walls, double-sided**

Huni unit length	Length mm	Art. no.	Art. no.	Art. no.	Art. no.	Art. no.	Art. no.	Art. no.
27 U	456	828.001	828.002	828.003	828.004	828.005	828.006	828.007
36 U	610	828.008	828.009	828.010	828.011	828.012	828.013	828.014
54 U	915	828.015	828.016	828.017	828.018	828.019	828.020	828.021
64 U	1085	-	828.028	828.029	828.030	828.031	828.032	-
78 U	1323	-	828.022	828.023	828.024	828.025	828.026	-

**Dividers**

3 U	48	828.041	828.042	828.043	-	-	-	-
4 U	65	828.044	828.045	828.046	-	-	-	-
5 U	82	828.047	828.048	828.049	-	-	-	-
6 U	98	828.050	828.051	828.052	828.053	-	-	-
7 U	116	828.054	828.055	828.056	828.057	828.058	-	-
8 U	133	828.059	828.060	828.061	828.062	828.063	828.064	-
9 U	149	828.065	828.066	828.067	828.068	828.069	828.070	828.071
10 U	167	828.072	828.073	828.074	828.075	828.076	828.077	828.078
12 U	201	828.079	828.080	828.081	828.082	828.083	828.084	828.085
15 U	252	828.086	828.087	828.088	828.089	828.090	828.091	828.092
18 U	303	828.093	828.094	828.095	828.096	828.097	828.098	828.099

Extruded screws for dividers: screws for fixing the dividers to the drawer bottom (100 pcs/set) 828,272

Front height of drawer	50 mm	75 mm	100, 125 mm	150, 175 mm	200 mm	250 mm	300, 450 mm
Clear height	31.5 mm	50 mm	75 mm	125 mm	175 mm	225 mm	275 mm

**Dividers, smooth**

Huni unit length	Length mm	Art. no.	Art. no.	Art. no.	Art. no.	Art. no.	Art. no.	Art. no.
27 U	457	828.117	828.118	828.119	828.120	828.121	828.122	-
36 U	610	828.128	828.129	828.130	828.131	828.132	828.133	828.134
54 U	915	828.135	828.136	828.137	828.138	828.139	828.140	828.141
78 U	1323	-	828.142	828.143	828.144	828.145	828.146	828.147

Barcode holder incl. Label cover for slotted walls and dividers including labels (size 40).

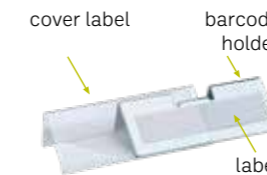

**Barcode holder**

Label size (W x H) mm	For drawer front height mm	Number	Art. no.
50 x 15	50 to 300	1	828.172
65 x 25	70 to 300	1	828.174

**Cover label**

Label size (W x H) mm	For drawer front height mm	Number	Art. no.
50 x 15	50 to 300	1	828.166
65 x 25	70 to 300	1	828.167

**Label cover set + barcode holder (5 pcs + 5 pcs)**

Label size (W x H) mm	For drawer front height mm	Number	Art. no.
50 x 15	50 to 300	5 + 5	828.178
65 x 25	70 to 300	5 + 5	828.179



### Perfect drawer partitioning

Store small and round components professionally and neatly in Huni drawers with Huni trays and troughs. The table on the right shows the maximum capacity of the drawer according to the dimensions of the trays and troughs. The dimensions are standardised, so you can choose your preferred combination because they fit into any Huni drawer. The height of the drawer front must be taken into account (exterior dimensions).

Particularly suitable for drawers with front heights of: 50, 75, 100, 125 mm.



ESD version on request.

### How can I divide up my Huni drawer?

Example: 36 × 27 E (612 × 459 mm) drawer trays and troughs

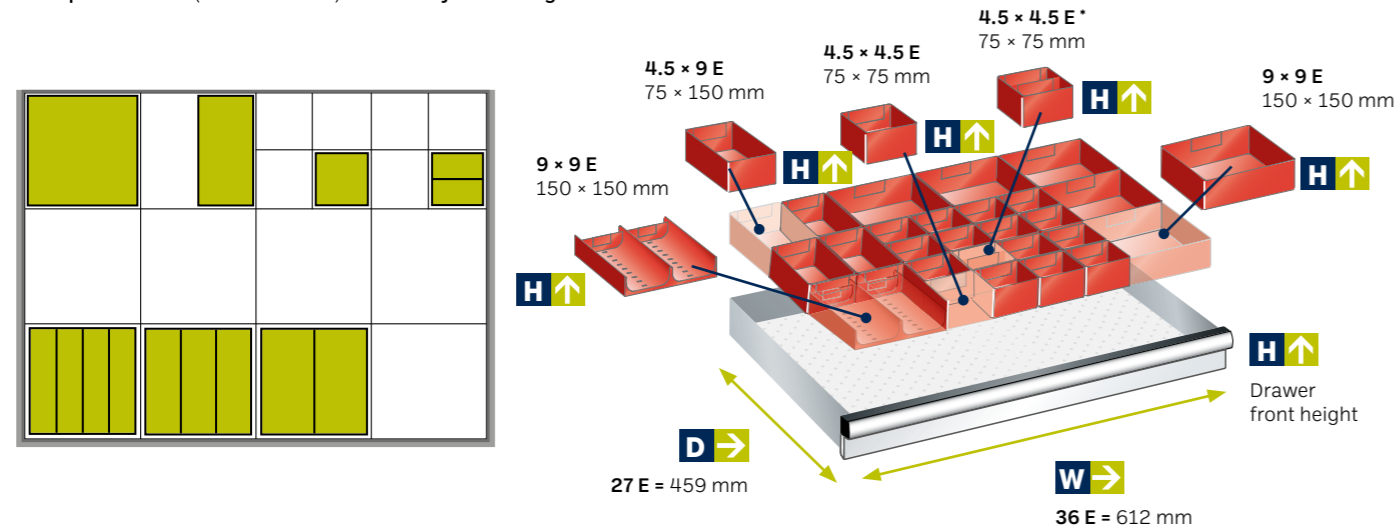

\* The tray also has a fixed center partition.

W → × D ↗	Maximum capacity per drawer with:		
	9 × 9 E 150 × 150 mm	4.5 × 9 E 75 × 150 mm	4.5 × 4.5 E 75 × 75 mm
27 × 27 E 459 × 459 mm	9	18	36
36 × 27 E 612 × 459 mm	12	24	48
54 × 27 E 918 × 459 mm	18	36	72
27 × 36 E 459 × 612 mm	12	24	48
36 × 36 E 612 × 612 mm	16	32	64
54 × 36 E 918 × 612 mm	24	48	96
64 × 36 E 1088 × 612 mm	28	56	112
78 × 36 E 1326 × 612 mm	32	68	136



### Tray, standard



Drawer front height (mm)	Height (mm)	9 × 9 E	4.5 × 9 E	4.5 × 4.5 E	4.5 × 4.5 E*
		150 × 150 mm	75 × 150 mm	75 × 75 mm	75 × 75 mm
50	26	Art. no. 828.197	Art. no. 828.194	Art. no. 828.192	Art. no. 828.191*
75	46	Art. no. 828.198	Art. no. 828.195	Art. no. 828.193	-
100	71	Art. no. 828.199	Art. no. 828.196	-	-

\* The tray also has a fixed center partition.

### Trough, standard



Trough components 9 × 9 E	9 × 9 E (150 × 150 mm)		
	ø 33 mm, 4 troughs	ø 45 mm, 3 troughs	ø 70 mm, 2 troughs
Trough separators	Art. no. 828.211	Art. no. 828.210	Art. no. 828.209
	Art. no. 828.216	Art. no. 828.215	Art. no. 828.214

Attention: Depending on the material to be stored, consider the drawer's usable height.

### Clip-on label holder for trays

Clip-on holder to be countersunk into the recess of the trays. Includes labels and transparent sheet.



Cover label		
Dimensions (W × H) mm	Number	Art. no.
42 × 15.4	20	828.181





**Anti-slide mats**

Anti-slide mats for the safe storage of delicate articles. To be countersunk into the drawer base. Description: PVC/nylon mesh mats. Colour: anthracite.

For drawers Unit size (U)	Width mm	Depth mm	Thickness mm	Art. no.
27 × 27	450	450	3	828.282
27 × 36, 36 × 27	450	600	3	828.283
36 × 36	600	600	3	828.284
54 × 27	900	450	3	828.287
54 × 36	900	600	3	828.285
64 × 36	1080	600	3	828.321
78 × 36	1320	600	3	828.286

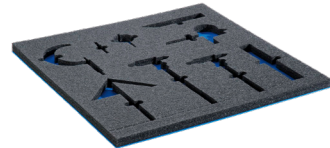

**Foam inserts**

They are used to store very delicate articles or articles of indeterminate form. The engraving knives can be used to achieve a precise contour. Description: polyethylene-plastic. Colour: black.

For drawers Unit size (U)	Width mm	Depth mm	Thickness mm	Art. no.
27 × 36, 36 × 27	600	447	22	828.570
36 × 36	600	600	22	828.571
54 × 27	906	447	22	828.573
54 × 36	906	600	22	828.572
78 × 36	1320	600	22	828.574

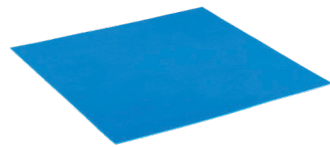

**Base for PE foam inserts**

Description: polyethylene-plastic. Colour: blue.

For drawers Unit size (U)	Width mm	Depth mm	Thickness mm	Art. no.
27 × 36, 36 × 27	600	447	3	828.580
36 × 36	600	600	3	828.581
54 × 27	906	447	3	828.583
54 × 36	906	600	3	828.582
78 × 36	1320	600	3	828.584

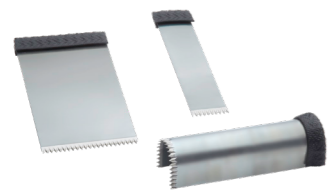

**Engraving knife for PE foam inserts**

For precise cutting of PE foam inserts, blank.

Width mm	Height mm	Art. no.
20	80	828.034
50	80	828.035
20 × 20 U-shape	80	828.036



**Milling cutter holder, height 26 mm**

The milling cutter holders can be extended as required by screwing them together. They are screwed to the perforated drawer base. Nuts included. Description: PP plastic. Colour: red.

For boring tool (DIN) Ø mm	Ø mm	Inch	Number	Art. no.
13	12.2	1/2	5	828.219
16	15.5	1/2	5	828.220
22	21.5	1/2	5	828.221
27	26.5	1/2	5	828.222
32	31.2	1/2	5	828.223
40	39.5	1/2	5	828.224
50	49.5	1/2	5	828.225



**Fastening pins**

For clamping irregularly shaped components. The fastening pins are screwed into the perforated drawer base. Nuts included. Description: round, galvanised, polished steel.

By height Front mm	Ø mm	Height mm	Number	Art. no.
50	6	27	10	828.239
75	6	52	10	828.240
100	6	77	10	828.241

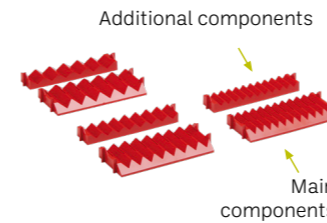

**Pairs of prismatic background**

Consisting of main and additional components. They are attached by threading them between two slotted walls. Delimitation with dividers. Slotted main components for precise subdivision or labelling with insertable foils. Description: PP plastic. Colour: red. Main component: width 153 mm/9 U, depth 68 mm/4 U. Additional component: width 153 mm/9 U, depth 34 mm/2 U.

Number of prismatic inserts	Max. tool Ø mm	Art. no.
6	20.5	828.207
8	15	828.206
11	10	828.205



**Pair of angular supports, height 52 mm**

The pairs of angular supports are screwed horizontally or vertically to the perforated drawer base. Includes screws. Description: PP plastic. Colour: red.

Width mm	Depth mm	Art. no.
25	75	828.250

**Huni** è una società del gruppo **LISTA**.  
Grazie alla sua **gamma completa**  
è in grado di fornire sia prodotti  
a marchio terzi che secondo  
le specifiche di clienti **OEM**.

**HUNI ITALIANA S.p.a.**

Sede legale e stabilimento: **Via Marconi, 12 - 24020 Colzate (BG)**

Ufficio Commerciale: **Tel. +39.035.737.440 - Fax +39.035.720.500**

**E-mail: [info@huni.com](mailto:info@huni.com) - [www.huni.com](http://www.huni.com)**



equipment  
**HUNI**  
italiana spa